

MEASURING INSTRUMENTS - STRUMENTI PER MISURARE



BOURDON TUBE PRESSURE GAUGE

NUOVA FIMA

bourdon tube pressure gauges standard execution DS 1.5", 2" (40-50mm)

MS1



They can be used with gaseous or liquid media which do not corrode copper alloy and which do not have high viscosity or do not cristalize.

1.01.1 - Standard Model, DS 1.5" (40mm)

Design: EN 837-1.

Ranges: from 0...30 to 0...600 *psi* (from 0...2,5 to 0...40 bar or equivalent units)

Accuracy class: 1,6 as per EN 837-1.

Ambient temperature: -13...+122°F (-25°C...+50°C).

Process fluid temperature : +149°F (+ 65 °C max).

Thermal drift: max ±0,4 % / 10 K of range (starting from 68°F - 20°C).

Working pressure:

75% of FSV for static pressure;

66% of FSV for pulsating pressure.

Overpressure (max 15 min):

25% of FSV for ranges ≤ 1500 *psi* (100 bar);

15% of FSV for ranges over 1500 *psi* (100 bar).

Protection degree: IP 40 as per IEC 529.

Socket material: copper alloy.

Bourdon tube: copper alloy.

Welding: copper alloy.

Case: stainless steel

Window: plastic.

Movement: copper alloy.

Dial: aluminium, white with black markings

Pointer: non adjustable, aluminium, black.

1.01.1 - Standard Model, DS 2" (50mm)

Ranges: from 0...30 to 0...6000 *psi* ; (from 0...2,5 to 0...400 bar or other equivalent units).

Ambient temperature: -13...+149°F (-25°C...+65°C).

Other features: as Standard Model, DS 1.5" (40mm).

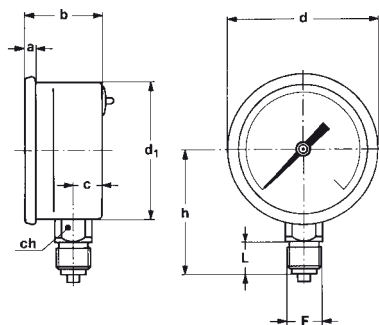

A - LOWER CONNECTION

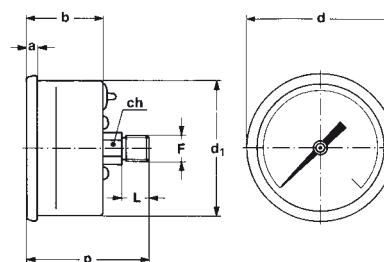

D - BACK CONNECTION

Mounting	DS	F	a	b	c	d	d ₁	h	p	L	ch	Weight
Back	A 1.5" (40)	11M - G 1/8 A		1.04"	0.43"	1.61"			1.77"	0.39"	0.47"	0.15 lbs
		13M - 1/8-27 NPT		(26,5)	(11)	(41)			(45)	(10)	(12)	(0,07 kg)
Lower	B 2" (50)	21M - G 1/4 A	0.15"	1.14"	0.43"	2.20"	2.00"			0.51"	0.55"	0.22 lbs
			(4)	(29)	(11)	(56)	(51)			(13)	(14)	(0,1 kg)
Lower	B 2" (50)	23M - 1/4-18 NPT	0.15"	1.14"		2.20"	2.00"	1.88"		0.59"	0.55"	0.22 lbs
			(4)	(29)		(56)	(51)	(47,9)		(15)	(14)	(0,1 kg)
Back	B 2" (50)	11M - G 1/8 A	0.15"	1.14"		2.20"	2.00"	1.88"	1.81"	0.39"	0.47"	0.18 lbs
		13M - 1/8-27 NPT	(4)	(29)		(56)	(51)	(47,9)	(46)	(10)	(12)	(0,085 kg)

dimensions : inches (mm)

"HOW TO ORDER" SEQUENCE

Section / Model / Case / Mounting / Diameter / Range / Process connection / Options

1 **01** **1** **A** **A** **11M**
 D **B** **13M**
 21M
 23M

bourdon tube pressure gauges

DS 6" (150mm)

MS1



CE Compliance to requirement of
PED 97/23/EC

They can be used with gaseous or liquid media which do not corrode copper alloy and which do not have high viscosity or do not cristalize.

1.01.1 - Standard Model

Design: EN837-1.

Safety designation: S1 as per EN 837-2.

Ranges: from 0...15 to 0...15000 *psi* (from 0...1 to 0...1000 bar or equivalent units).

Accuracy class: 1,6 as per EN 837-1.

Ambient temperature: -13...+149°F (-25...+65 °C).

Process fluid temperature:

13...+149°F (-25...+65 °C) for ranges ≤ 600 *psi* (40 bar);

-13...+ 248°F (-25...+120 °C) for ranges ≥ 1000 *psi* (60 bar).

Thermal drift: max ±0,4 % / 10 K of range (starting from +68°F - 20°C).

Working pressure:

75% of FSV for static pressure;

66% of FSV for pulsating pressure.

Overpressure (max 15 min):

25% of FSV for ranges ≤ 1500 *psi* (100 bar);

15% of FSV for ranges more than 1500 *psi* (100 bar).

Protection degree: IP 44 as per IEC 529.

Socket material: copper alloy, internal restrictor Ø 0.03" (0,8 mm).

Bourdon tube: copper alloy for ranges ≤ 600 *psi* (40 bar);
AISI 316L st.st. for ranges > 1000 *psi* (60 bar).

Case: stainless steel.

Ring: stainless steel, bayonet lock

Window: tempered glass.

Movement: copper alloy.

Dial: aluminium, white with black markings

Pointer: non adjustable, aluminium, black

bourdon tube pressure gauges

DS 6" (150mm)

MS1

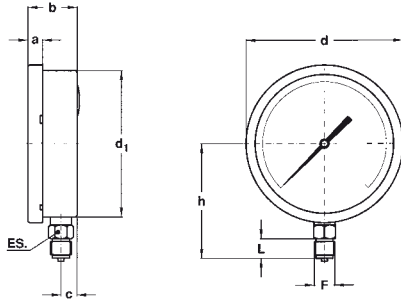

A - LOWER CONNECTION

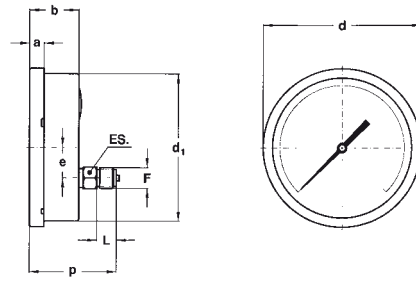

D - BACK CONNECTION

Mounting	F	a	b	c	d	d ₁	e	h	p	L	ES	Weight
Lower	41M - G 1/2 A	0.59"	1.98"	0.16"	6.33"	5.88"		4.60"		0.78"	0.86"	2.44 lbs
	43M - 1/2-14 NPT	(15)	(50,5)	(16,5)	(161)	(149,6)		(117)		(20)	(22)	(1,11 kg)
Back	41M - G 1/2 A	0.59"	1.98"		6.33"	5.88"	1.22"		3.50"	0.78"	0.86"	2.20 lbs
	43M - 1/2-14 NPT	(15)	(50,5)		(161)	(149,6)	(31)		(89)	(20)	(22)	(1,0 kg)

dimensions : inches (mm)

OPTIONS

B - "U"-clamp, for back connection pressure gauges
C - Back flange, for lower connection pressure gauges
E - Front flange, for back connection pressure gauges
K10 - Accuracy class 1,0%
L21 - Maximum pointer IP 44 on plexiglas window (1)
T32 - Safety glass window

(1) Accuracy refers to the area free from the maximum pointer action.

"HOW TO ORDER" SEQUENCE

Section / Model / Case / Mounting / Diameter / Range / Process connection / Options

1 01 1 A G 41M B, C, E
D 43M K10...T32

bourdon tube pressure gauges

anti-vibration version

DS 4" (100mm)

MS4

- Laser calibration up to 400bar
- Free zero
- Fillable with glycerine "on site"
- Safety plug



CE Compliance to requirement of
PED 97/23/EC

Instruments designed for use on power units, pump, hydro-cleaning machines, presses, engine compressors, turbines, diesel engines, chemical, petrochemical and refrigerating plants and on machines and equipment where pulsating pressures or mechanical vibrations are apparent. They can be used with gaseous or liquid media which do not corrode copper alloy and which do not have high viscosity or do not cristalize.

1.04.2 - Fillable Model

Design: EN 837-1.

Safety designation: S1 as per EN 837-2.

Ranges: from 0...15 to 0...15000 PSI (from 0...1 to 0...1000 bar or other equivalent units).

Accuracy class: 1,6 as per EN 837-1.

Ambient temperature: -13...+149°F (-25...+65 °C).

Process fluid temperature: +212 °F (max +100 °C).

Thermal drift: max ±0,4 % / 10 K of ranges (starting from 68°F- 20°C).

Working pressure:

75% of FSV for static pressure;

66% of FSV for pulsating pressure.

Overpressure (max 15 min):

25% of FSV of ranges ≤ 1500 psi (100 bar);

15% of FSV for ranges over 1500 psi (100 bar).

Protection degree: IP 67 as per IEC 529.

Socket material: copper alloy, with internal restrictor ø 0.03" (0,8 mm)

Bourdon tube:

copper alloy for ranges ≤ 10000 psi (600 bar);

AISI 316L st.st. for ranges 15000 psi (1000 bar).

Case: stainless steel.

Ring: stainless steel, polished , crimped.

Window: tempered glass.

Movement: copper and stainless steel.

Dial: aluminium, white with black markings

Pointer: not adjustable, aluminium,black

1.04.3 - Filled Model

Damping liquid: glycerine 98%, silicon oil.

Ambient temperature:

+59...+149 °F (+15...+65 °C) with glycerine filling;

-22...+149 °F (-30...+65 °C) with silicon oil filling.

Process fluid temperature: max+149°F (+65°C) .

Other features: as Fillable Model.

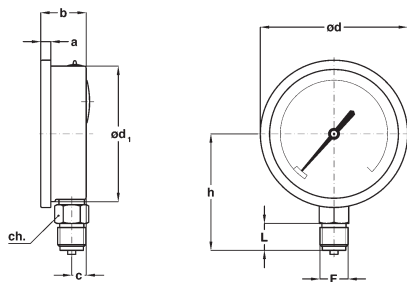

A - LOWER CONNECTION

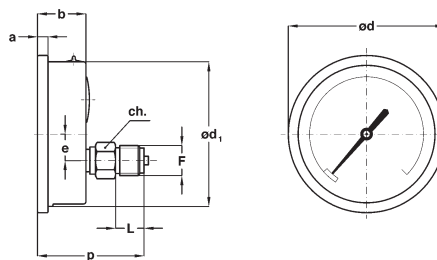

D - BACK CONNECTION

Mounting	F	a	b	c	d	d ₁	e (3)	h	p	ch	L	Weight
Lower	41M - G 1/2 A	0.29"	1.33"	0.43"	4.33"	3.97"		3.42"		0.86"	0.78"	0.88 lbs (1)
	43M - 1/2-14 NPT	(7,5)	(34)	(11)	(110)	(101)		(87)		(22)	(20)	(0,4 kg)
Back	41M - G 1/2 A	0.29"	1.33"		4.33"	3.97"	1.14"		2.95"	0.86"	0.78"	0.79 lbs (2)
	43M - 1/2-14 NPT	(7,5)	(34)		(110)	(101)	(29)		(75)	(22)	(20)	(0,36 kg)

(1) Add 0.5 lbs (0,23 kg) when filled - (2) Add 0.53 lbs (0,24 kg) when filled - (3) quote "e" will become 0,73 lbs (18,5 mm) within 2009

OPTIONS

Model	fillable	filled
B - "U"-clamp, for back connection pressure gauges	◆	◆
C - Back flange, for lower connection pressure gauges	◆	◆
E - Front flange, for back connection pressure gauges	◆	◆
P01 - Suitable for filling with silicone	◆	
S06 - Restrictor plug ϕ 0.01" (0,4 mm)	◆	◆
S10 - Silicone filling		◆

"HOW TO ORDER" SEQUENCE

Section / Model / Case / Mounting / Diameter / Range / Process connection / Options
1 **04** **2** **A** **E** **41M** **B, C, E**
3 **D** **43M** **P01...S10**

bourdon tube pressure gauges anti-vibration version DS 2" (50mm)

MGS10

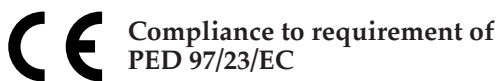

Compliance to requirement of
PED 97/23/EC

Instruments designed for use on power units, pumps, hydro-cleaning machines, presses, engine compressors, turbines, diesel engines, chemical, petrochemical and refrigerating plants and on machines and equipment where pulsating pressures or mechanical vibrations are apparent. They can be used with gaseous or liquid media which do not corrode copper alloy and which do not have high viscosity or do not cristalize.

1.10.2 - Fillable Model

Design: EN 837-1.

Ranges: *from 0...30 to 0...6000 psi* (from 0...2,5 to 0...400 bar)

Accuracy class: 1,6 as per EN 837-1.

Ambient temperature: -13...+149°F (-25...+65 °C).

Process fluid temperature: +248°F (max +120 °C).

Thermal drift: max ±0,4 %/10 °C of ranges (starting from +68°F - 20°C).

Working overpressure:

75% of FSV for static pressure;

66% of FSV for pulsating pressure;

Overpressure (max 15 min):

25% of FSV of ranges ≤ 1450 psi (100 bar);

15% of FSV for ranges over 1450 psi (100 bar).

Protection degree: IP 65 as per IEC 529.

Socket material: copper alloy.

Bourdon tube: copper alloy.

Case: stainless steel.

Window: plastic.

Movement: copper alloy.

Dial: aluminium, white with black markings.

Pointer: not adjustable, aluminium, black

1.10.3 - Filled Model

Damping liquid: glycerine 98%.

Ambient temperature: +32...+149°F (0...+65 °C).

Process fluid temperature: +149°F (max +65 °C).

Other features: as fillable model.

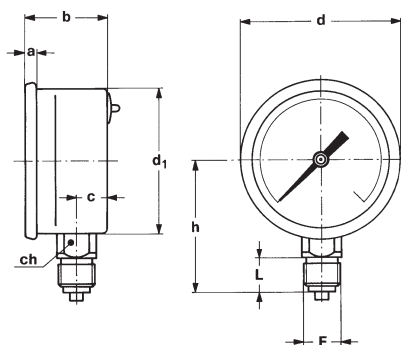

A - LOWER CONNECTION

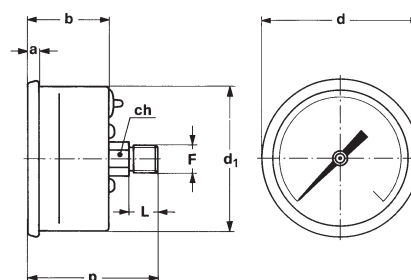

D - BACK CONNECTION

Mounting	F	a	b	c	d	d ₁	h	p	L	ch	Weight (1)
Lower	21M - G 1/4 A	0.15"	1.14"	0.43"	2.20"	2.00"	1.87" - 1.94"		0.51" - 0.59"	0.55"	0.22 lbs
	23M - 1/4-18 NPT	(4)	(29)	(11)	(56)	(51)	(47,5 - 49,5)		(13 - 15)	(14)	(0,1 kg)
Back	11M - G 1/8 A	0.15"	1.14"		2.20"	2.00"		1.81"	0.39"	0.47"	0.18 lbs
	13M - 1/8-27 NPT	(4)	(29)		(56)	(51)		(46)	(10)	(12)	(0,085 kg)

dimensions : inches (mm)

(1) add 0.09 lbs (0,045 kg) when filled

OPTIONS

Model	fillable	filled
B - Clamp and ring for back connection pressure gauges	◆	◆

"HOW TO ORDER" SEQUENCE

Section / Model / Case / Mounting / Diameter / Range / Process connection / Options

1 10 2 A B 11M B
 3 D 13M
 21M
 23M

bourdon tube pressure gauges anti-vibration version DS 2.5" (63mm)

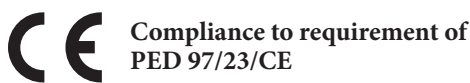

These instruments are built in conformity with the construction and safety S2 specifications of **EN 837-1**.

Instruments designed for use on power units, pump, hydro-cleaning machines, presses, engine compressors, turbines, diesel engines, refrigerating plants and on machines and equipment where pulsating pressures or mechanical vibrations are apparent. They can be used with gaseous or liquid media which do not corrode copper alloy and which do not have high viscosity or do not cristalize.

1.10.2 - Fillable Model

Design: EN837-1.

Safety designation: S2 as per EN 837-1.

Ranges: from 0...15 to 0...10000 psi (from 0...1 to 0...600 bar or other equivalent units).

Accuracy class: 1,6 as per EN 837-1.

Ambient temperature: -13...+149°F (-25...+65 °C).

Process fluid temperature: +212°F (max +100 °C).

Thermal drift: max ±0,4 %/10 °C of ranges
(starting from + 68 °F - 20 °C).

Working pressure:

75% of FSV for static pressure;

66% of FSV for pulsating pressure.

Over pressure limit (15 min max):

25% of FSV for pressure ranges ≤ 1500 psi (100 bar);

15% of FSV for pressure ranges over 1500 psi (100 bar).

Protection degree: IP 67 as per EN 60529/IEC 529.

Socket material: copper alloy.

Bourdon tube: copper alloy.

Case: stainless steel.

Ring: stainless steel, polished, crimped

Window: polycarbonate.

Movement: copper and stainless steel.

Dial: plastic, white with black markings

Pointer: not adjustable, aluminium, black

1.10.3 - Filled Model

Damping liquid: glycerine 98% or silicon oil.

Ambient temperature:

+32...+149 °F (0...+65 °C) with glycerine filling;

-40...+149 °F (-40...+65 °C) with silicon oil filling.

Process fluid temperature: max +149°F (+65 °C).

Other features: as fillable model.

bourdon tube pressure gauges
anti-vibration version, DS 2.5" (63mm)

MGS10

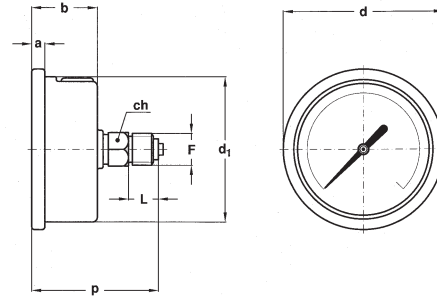
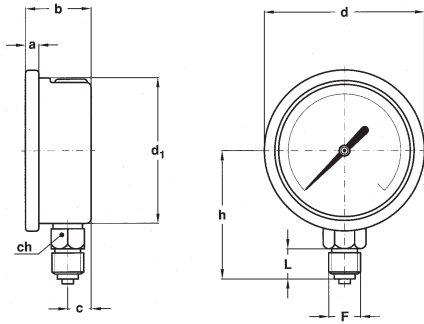

A - LOWER CONNECTION

D - BACK CONNECTION

Mounting	F	a	b	c	d	d ₁	h	p	L	ch	Weight (1)
Lower	21M - G 1/4 A	0.22"	1.10"	0.39"	2.67"	2.46"	2.17" - 2.13"		0.51"	0.51" x 0.35"	0.28 lbs
	23M - 1/4-18 NPT	(5,6)	(28)	(10)	(68)	(62,6)	(55,3 - 54,3)		(13)	(14 x 9)	(0,13 kg)
Back	21M - G 1/4 A	0.22"	1.10"		2.67"	2.46"		1.81" - 2.11"	0.39"	0.51" x 0.35"	0.30 lbs
	23M - 1/4-18 NPT	(5,6)	(28)		(68)	(62,6)		(54,8 - 53,8)	(13)	(14 x 9)	(0,14 kg)

dimensions : inches (mm)

(1) add 0.15 lbs (0,07 kg) when filled

OPTIONS

Model	fillable	filled
B - "U"-clamp, for back connection pressure gauges	◆	◆
C - Back flange, for lower connection pressure gauges	◆	◆
E - Front flange, for back connection pressure gauges	◆	◆
Q03 - Dial: aluminium (min. 100 pz)	◆	◆
S06 - Restrictor plug ø 0.015 " (0,4 mm).	◆	◆
P01 - Suitable for filling with silicone	◆	
S10 - Silicone filling		◆
T37 - Tempered glass window (1)	◆	◆

(1) Safety designation: S1 as per EN 837-1.

"HOW TO ORDER" SEQUENCE

Section / Model / Case / Mounting / Diameter / Range / Process connection / Options

1 **10** **2** **A** **C** **21M** **B, C, E**
3 **D** **23M** **Q03...T37**



bourdon tube pressure gauges anti-vibration heavy duty version DS 4" (100mm)

MGS10



Instruments designed for use on power units, pumps, hydro-cleaning machines, presses, engine compressors, turbines, diesel engines, chemical, petrochemical and refrigerating plants and on machines and equipment where pulsating pressures or mechanical vibrations are apparent. They can be used with gaseous or liquid media which do not corrode copper alloy and which do not have high viscosity or do not cristalize.

1.10.1 - Standard Model

Design: EN 837-1.

Safety designation: S1 as per EN 837-2.

Ranges: from 0...15 to 0...15000 PSI (from 0...1 to 0...1000 bar or other equivalent units).

Accuracy class: 1,0 as per EN 837-1.

Ambient temperature: -40...+149 °F (-40...+65 °C)

Process fluid temperature:

-13...+212 °F (-25...+100 °C) for ranges ≤ 600 psi (40 bar);

-13...+248 °F (-25...+120 °C) per campi ≥ 600 psi (40 bar).

Thermal drift: $\pm 0,4$ % / 10 °C of range (starting from 68°F - 20°C).

Working pressure:

100% of FSV for static pressure;

90% of FSV for pulsating pressure.

Overpressure limit: 30% of FSV (max 12 h).

Protection degree: IP 55 as per IEC 529.

Socket material:

copper alloy with internal restrictor $\varnothing 0.03$ " (0,8 mm).

Bourdon tube:

copper alloy for ranges ≤ 600 psi (40 bar);

AISI 316L st.st.for ranges > 600 psi (40 bar).

Case: stainless steel.

Ring: stainless steel, bayonet lock

Window: tempered glass

Movement: copper.

Dial: aluminium, white with black markings

Pointer: not adjustable, aluminium ,black

1.10.2 - Fillable Model

Protection degree: IP 67 as per IEC 529.

Other features: as Standard Model.

1.10.3 - Filled Model

Damping liquid: glycerine 98% or silicon oil.

Ambient temperature:

+32...+149 °F (0...+65 °C) with glycerine filling;

-40...+149 °F (-40...+65 °C) with silicon oil filling.

Process fluid temperature: max +149°F (+65 °C).

Protection degree: IP 67 as per IEC 529.

Other features: as Standard Model

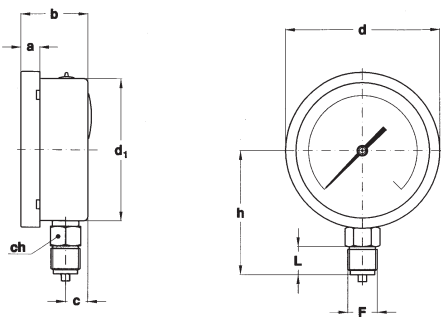

A - LOWER CONNECTION

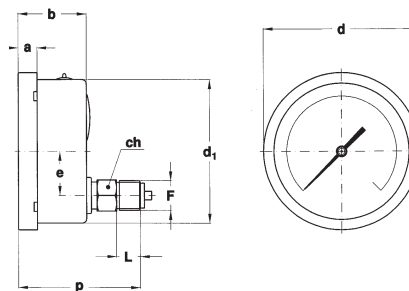

D - BACK CONNECTION

Mounting	F	a	b	c	d	d ₁	e	h	p	ch	L	Weight (1)
Lower	41M - G 1/2 A	0.51"	1.91"	0.63"	4.35"	3.97"		3.38"		0.86"	0.78"	1.14 lbs
	43M - 1/2-14 NPT	(13)	(48,6)	(16,1)	(110,6)	(101)		(86)		(22)	(20)	(0,52 kg)
Back	41M - G 1/2 A	0.51"	1.91"		4.35"	3.97"	1.22"		3.41"	0.86"	0.78"	1.25 lbs
	43M - 1/2-14 NPT	(13)	(48,6)		(110,6)	(101)	(31)		(86,8)	(22)	(20)	(0,57 kg)

dimensions : inches (mm)

(1) add 0.72 lbs (0,33 kg) when filled

OPTIONS

Model	standard	fillable	filled
B - "U"-clamp, for back connection pressure gauges	♦	♦	♦
C - Back flange, for lower connection pressure gauges	♦	♦	♦
E - Front flange, for back connection pressure gauges	♦	♦	♦
L22 - Maximum pointer IP 67 on polycarbonate window (1)		♦	♦
P01 - Suitable for filling with silicone		♦	
S10 - Silicone filling			♦
T32 - Safety glass window	♦	♦	♦

(1) Accuracy refers to the area free from the maximum pointer action.

"HOW TO ORDER" SEQUENCE

Section / Model / Case / Mounting / Diameter / Range / Process connection / Options

1 **10** **1** **A** **E** **41M** **B, C, E**
 2 **D** **43M** **L22...T32**
 3

bourdon tube "solid-front" pressure gauges

turret case

DS 4.5" (125 mm)

MGS30



These instruments are built in conformity with the construction and safety specifications of **ASME B40.1**. In case of leaks or break of the elastic element the operator is protected by a stainless steel safety cell solid front and by the blow-out back. They are usually used in the chemical, petrochemical industries and in conventional power plants. The TIG welding between the safety cell and the process socket strengthens the instrument and assures a better tight in case of dampening fluid. The advantages of filling the case of the instrument with a dampening fluid are: reduced pointer fluctuation, reduced wear of rotating parts of the movement when pulsant vibrations and pulsations occur. Moreover condensation and corrosive atmospheres which could damage the internal parts.

1.30.2 - Fillable Model - Lower connection only

Design: ASME B40.1
Ranges: from 0...15 to 0...30000 psi; (from 0...0,6 to 0...1600 bar or other equivalent units).
Accuracy: 2A grade as per ASME B40.1 ($\pm 0,5\%$ of FSV).
Ambient temperature: -13...+149°F (-25...+65°C).
Process fluid temperature: -22...302°F (-30...+150°C max).
Working pressure:
100% del FSV for static pressure;
90% del FSV for pulsating pressure.
Overpresssure: 30% of FSV (max 12 h).
Protection degree: IP 67 as per IEC 529.
Socket material: AISI 316L st.st.
Bourdon tube: AISI 316L st.st. seamless tube.
Case and blow out disk: strengthened polyammides with fiber glass , UV rays stabilized.
Ring: strengthened polypropylene, fiber glass.
Safety cell: stainless steel.
Window: tempered glass.
Movement: stainless steel with internal limit stops for minimum and maximum pressure.
Dial: aluminium, white with black markings.
Pointer: adjustable, aluminium, black.

1.30.3 - Filled Model - Lower connection only

Ranges: from 0...15 to 0...30000 psi; (from 0...1 to 0...1600 bar or other equivalent units).
Accuracy: 1A grade as per ASME B40.1 ($\pm 1,0\%$ of FSV).
Filling liquid: glycerine 98%, and silicon oil or Fluorinated fluid on request.
Ambient temperature:
+32...+149°F (0...+65 °C) with glycerine filling;
-40...+149°F (-40...+65 °C) with silicon oil filling;
-40...+149°F (-40...+65 °C) with fluorinated fluid filling.
Process fluid temperature: +149°F (+65 °C).
Compensating device: gum.
Other features: as Fillable Model.

1.30.1 - Standard Model - Back connection only

Protection degree: IP 55 as per IEC 529.
Case: phenolic resin.
Ring and blow out disk: strengthened polypropylene, fiber glass.
Safety cell: not available.
Separating wall: phenolic resin.
Other features: as Fillable Model.

OXYGEN INSTRUMENTS

Glycerine and silicon oil should not be used with highly oxydizing agents as oxygen, chlorine, nitric acid or hydrogrn peroxide because of danger of spontaneous chemical reaction, inflammability or explosion. The use of fluorinates fluid is recommended in these cases.

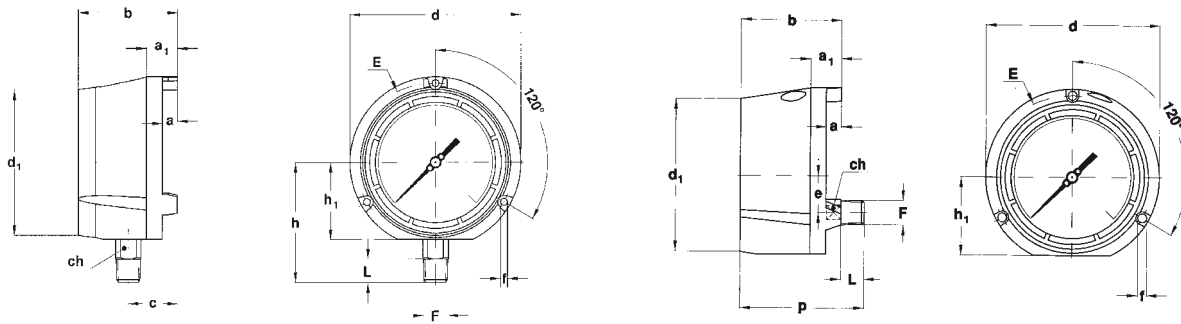

A - LOWER CONNECTION

D - BACK CONNECTION

Mounting	F	a	a ₁	b	c	d	d ₁	e	E	f	h	h ₁	ch	p	Weight (1)
Lower	41M G 1/2 A	0.51" (13)	1.06" (27)	3.38" (86)	1.65" (42)	5.82" (148)	4.96" (126)		5.39" (137)	0.25" (6,5)	4.07" (103,5)	2.61" (66,5)	0.86" (22)		0.78" (20) 1.78 lbs (0,81 kg)
Back	43M 1/2-14 NPT	0.51" (13)	1.06" (27)	3.38" (86)		5.82" (148)	5.07" (129)	1.22" (31)		0.23" (6)		2.61" (66,5)	0.66" (17)	4.17" (106)	0.78" (20) 1.78 lbs (0,81 kg)

dimensions : inches (mm)

(1) add 1.10 lbs (0,5 kg) when filled.

OPTIONS

Model	standard	fillable	filled
F11 - Panel mounting kit	◆	◆	◆
F30 - Fluorinated fluid filling			◆
P01 - Suitable for silicone filling		◆	
P02 - Oxygen service (3)	◆	◆ (1)	◆ (2)
FDP - Blow out disk with compensating device		◆	
F30 - Over pressure limit: 50% of FSV for pressure ranges < 6000 psi (400 bar)	◆	◆	◆
S10 - Silicone filling			◆
T01 - Tropicalization	◆	◆	◆
T32 - Safety glass window	◆	◆	◆

(1) to be ordered with instruments suitable for fluorinated fluid filling
(2) to be ordered with fluorinated fluid filled instruments

(3) For pressure ranges up to 15000 psi (1000 bar)

"HOW TO ORDER" SEQUENCE

Section / Model / Case / Mounting / Diameter / Range / Process connection / Options
1 30 1 A F 41M K03...T32
2 D 43M
3

pressure gauges "solid-front" turret case DS 4.5" (125mm)

MGS30 EXTRA

- thermoplastic case
- AISI 316L wetted parts
- dampened movement
- vibrations proof



These instruments are built in accordance with safety specifications ASME B40.1, UNI-EN 837-2.

The safety construction consists of a stainless steel "solid-front" safety cell placed behind the scale, which welding to socket gives to instrument an exceptional strength. Whenever, due to leaks, an internal pressure is created or the elastic element is broken the safety cell protects the front and sides, meanwhile the blow out back is released from the case. They are designed for use in chemical, petrochemical, conventional power plants. The dampened movement make them particularly suitable in presence of high vibrations and pulsating pressure.

1.30.X.A - Standard Model - Lower Connection

Design: ASME B40.1

Ranges: from 0...30 to 0...15000 psi; (from 0...2,5 to 0...1000 bar or other equivalent units).

Accuracy: Grade 2A as per ASME B40.1 ($\pm 0,5\%$ of span).

Ambient temperature: -13...+149°F (-25...+65°C).

Process fluid temperature: -22...302°F (-30...+150°C max).

Working pressure: max 75% of FSV.

Overpressure: (temporary): 30% of FSV.

Protection degree: IP 65 as per EN 60529/IEC 529.

Socket material: AISI 316 L.

Elastic element: AISI 316L seamless tube.

Case and blow out disk: polyamide, fiberglass reinforced, UV ray stabilized.

Ring: polypropylene, fiberglass reinforced.

Safety cell: AISI 304 st.st.

Window: tempered glass.

Movement: stainless steel, dampened.

Dial: aluminium, white with black markings.

Pointer: aluminium, micrometric adjustable.

1.30.X.D - Standard Model - Back Connection

Protection degree: IP 65 as per EN 60529/IEC 529.

Case: phenolic resin.

Ring and blow out disk: polypropylene, fiberglass reinforced.

Separating wall: AISI 304 st.st.

Safety cell: not available.

Other features: as lower connection.

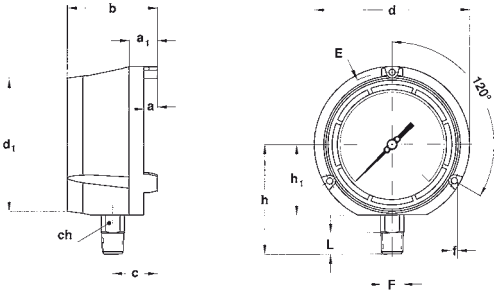

A - LOWER CONNECTION

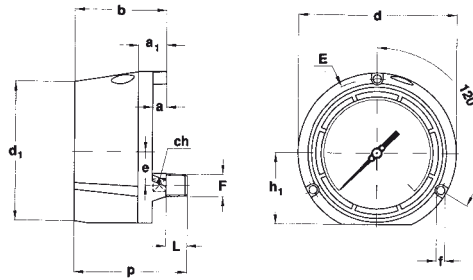

D - BACK CONNECTION

Mounting	F	a	a ₁	b	c	d	d ₁	e	E	f	h	h ₁	ch	p	L	Weight (1)
Lower	23M -1/4-18 NPT	0.51"	1.06"	3.38"	1.65"	5.82"	4.96"		5.39"	0.25"	4.07"	2.61"	0.86"		0.78"	1.78 lbs
	43M -1/2-14 NPT	(13)	(27)	(86)	(42)	(148)	(126)		(137)	(6,5)	(103,5)	(66,5)	(22)		(20)	(0,81 kg)
Back	23M -1/4-18 NPT	0.51"	1.06"	3.38"		5.82"	5.07"	1.22"		0.23"		2.61"	0.66"	4.17"	0.78"	2.20 lbs
	43M -1/2-14 NPT	(13)	(27)	(86)		(148)	(129)	(31)		(6)		(66,5)	(17)	(106)	(20)	(1,0 kg)

dimensions : inches (mm)

OPTIONS

F11 - Panel mounting Kit
T01 - Tropicalization
T25 - AISI 316 st.st. label
T32 - Safety glass window

“HOW TO ORDER” SEQUENCE

Section / Model / Case / Mounting / Diameter / Range / Process connection / Options
1 **30** **X** **A** **F** **23M** **F11...T32**
 D **43M**

bourdon tube "solid-front" pressure gauges for high pressures, turret case DS 4.5" (125 mm)

MGS32



These instruments are built in conformity with the construction and safety specifications of **ASME B40.1**.

In case of leaks or break of the elastic element the operator is protected by a stainless steel safety cell solid front and by the blow-out back. They are mainly used on high pressure water jet technology like water cutting machines, hydro blasting pumps and turbines, hydrodemolition. The TIG welding between the safety cell and the process socket strengthens the instrument and assures a better tight in case of dampening fluid. The advantages of filling the case of the instrument with a dampening fluid are: reduced pointer fluctuation, reduced wear of rotating parts of the movement when pulsant vibrations and pulsations occur. Moreover condensation and corrosive atmospheres which could damage the internal parts.

1.32.2 - Fillable Model

Ranges: 0...2500, 0...3000 and 0...4000 bar;
0...30000, 0...40000 and 0...60000 psi/bar.

Accuracy: Grade 1A as per ASME B40.1 ($\pm 1,0\%$ of F.S.V.).

Ambient temperature: -13...+149 °F (-25...+65 °C).

Process fluid temperature: -22...+302 °F (-30...+150 °C).

Working pressure:

75% of FSV for static pressure;

66% of FSV for pulsating pressure.

Over pressure limit: 10% of FSV (temporary).

Protection degree: IP 67 as per IEC 529.

Socket material: AISI 316L st.st.

Bourdon tube: duplex st.st. seamless tube.

Case and blow out disk: strengthened polyammides with fiber glass, UV rays stabilized.

Ring: strengthened polypropylene, fiber glass.

Safety cell: stainless steel.

Window: safety glass.

Movement: stainless steel with internal limit stops for minimum and maximum pressure.

Dial: aluminium, white with black markings.

Pointer: adjustable, aluminium, black.

1.32.3 - Filled Model

Damping liquid: glycerine 98%, silicon oil.

Ambient temperature:

+32...+149 °F (0...+65 °C) with glycerine filling;

-22...+149 °F (-30...+65 °C) with silicon oil filling.

Process fluid temperature: max +149°F (+65 °C).

Other features: as Fillable Model.

**bourdon tube "solid-front" pressure gauges, for high pressures
turret case DS 4.5" (125 mm)**

MGS32

R80 - 04/08

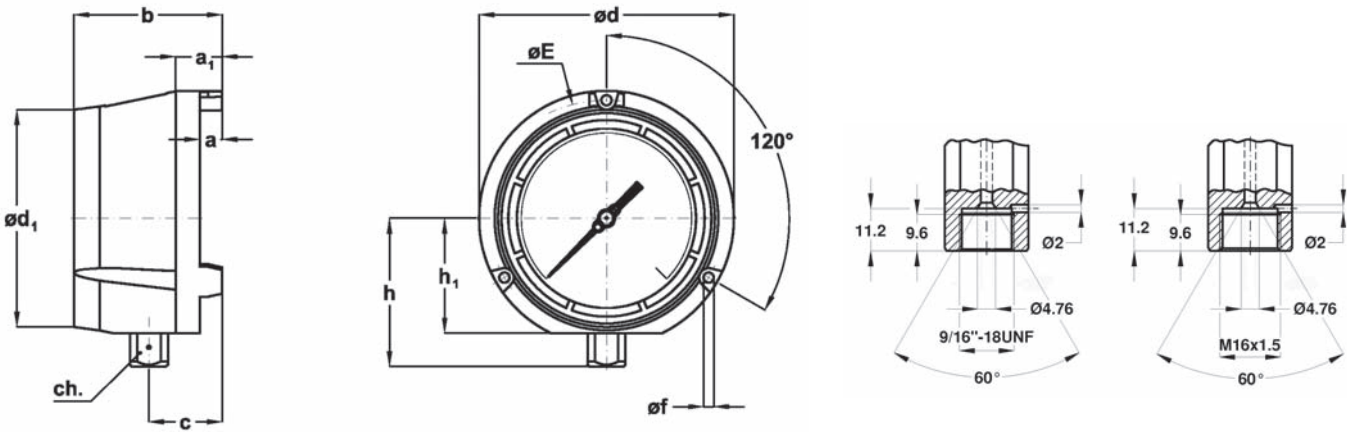

A - LOWER CONNECTION

Mounting	F	a	a ₁	b	c	d	d ₁	E	f	h	h ₁	ch	Peso (1)
Lower	IUF 9/16-18 UNF-2B (1) D7F M16 x 1,5	13	27	86	42	148	126	137	6,5	86	66,5	22	0,75 kg

(1) suitable for following fittings:

- 1/4" F250C Autoclave
- 1/4" HF4 - HiP
- 1/4" Newport AMINCO HP
- 1/4" HP Butech

(2) add 1.10 Ibs (0,5 kg) when filled.

dimensions : mm

OPTIONS

Model	fillable	filled
F11 - Panel mounting kit	◆	◆
P01 - Suitable for filling with silicon and "Fluorolube"	◆	
S10 - Silicone filling		◆
T01 - Tropicalization	◆	◆

"HOW TO ORDER" SEQUENCE

Section / Model/Case /Mounting/ Diameter / Range / Process connection / Options
1 32 2 A F D7F F11...T01
3 IUF

bourdon tube pressure gauges
aluminium case
DS 10" (250 mm)

MGS8



These instruments are designed for use in chemical and petrochemical processing industries, and in conventional power plants, built to resist the most severe operating conditions, to measure gaseous or liquid media which do not have high viscosity or do not crystallize.

1.08.1 - Standard Model

Design: EN837-1.

Safety designation: S1 as per EN 837-2.

Ranges: from 0...1 to 0...1000 bar (or other equivalent units).

Accuracy class: 1 as per EN 837-1.

Ambient temperature: -13...+149 °F (-25...+65 °C).

Process fluid temperature: -40...+302 °F (-40...+150 °C).

Thermal drift: ±0,4 % / 10 K of range (starting from 68°F - 20°C).

Working pressure:

100% of FSV for static pressure;

90% of FSV for pulsating pressure.

Over pressure limit: 30% of FSV (max 12 hours).

Protection degree: IP 55 as per EN 60529 / IEC 529.

Socket material: AISI 316L st.st.

Bourdon tube: AISI 316L st.st. seamless tube.

Case: black painted aluminium.

Ring: black painted aluminium.

Window: tempered glass.

Movement: stainless steel.

Dial: aluminium, white with black markings.

Pointer: not adjustable, aluminium, black.

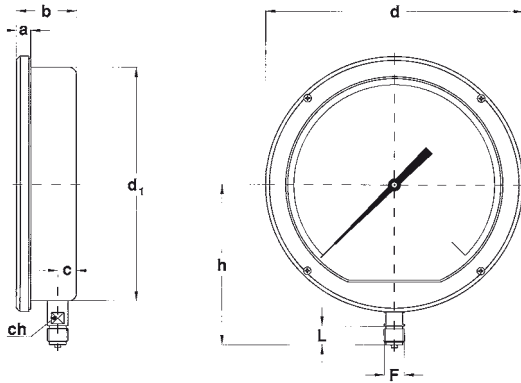

A - LOWER CONNECTION

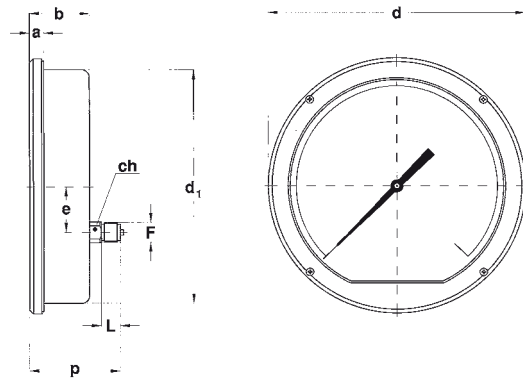

D - BACK CONNECTION

Mounting	F	a	b	c	d	d ₁	e	h	p	ch	L	Weight
Lower	41M - G 1/2 A	0.59"	2.48"	0.76"	10.62"	9.72"		6.69"		0.66"	0.78"	6.83 lbs
	43M - 1/2-14 NPT	(15)	(63)	(19,5)	(270)	(247)		(170)		(17)	(20)	(3,1 kg)
Back	41M - G 1/2 A	0.59"	2.48"		10.62"	9.72"	1.88"		3.37"	0.86"	0.78"	7.16 lbs
	43M - 1/2-14 NPT	(15)	(63)		(270)	(247)	(47,8)		(95,5)	(22)	(20)	(3,25 kg)

OPTIONS

K06 - Accuracy class 0.6 as per EN 837-1(1)
P02 - Oxygen service

(1) available only for ranges from 0...30 to 0...600 psi (from 0...2,5 to 0...400 bar)

"HOW TO ORDER" SEQUENCE

Section / Model / Case / Mounting / Diameter / Range / Process connection / Options
1 08 1 A I 41M K06...P02
D 43M

bourdon tube pressure gauges all stainless steel construction DS 1.5", 2" (40-50 mm)

MGS18



These instruments are designed for use in chemical and petrochemical processing industries, and in conventional power plants, to measure gaseous or liquid media which do not have high viscosity or do not cristalize. They are built to resist the most severe operating conditions created by the ambient environment and the process medium. For use on power units, pumps, hydro-cleaning machines, presses, engine compressors, turbines, diesel engines, chemical, petrochemical and refrigerating plants and on machines and equipment where pulsating pressures or mechanical vibrations are apparent, the liquid-filled version is recommended.

01.18.1 - Standard Model, DS 1.5" (40mm)

Design: EN 837-1.

Ranges: from 0...30 to 0...600 psi (from 0...2.5 to 0...40 bar or equivalent units).

Accuracy class: 1.6 as per EN 837-1.

Ambient temperature: -13...+149 °F (-25...+65 °C).

Process fluid temperature: -22...+212 °F (-30...+100 °C).

Thermal drift: ±0,4 % / 10 °C of range (starting from 68°F - 20°C).

Working pressure:

75% of FSV for static pressure;

66% of FSV for pulsating pressure.

Over pressure limit (15 min max):

25% of FSV.

Protection degree: IP 55 as per EN 60529/IEC 529.

Socket material: AISI 316L st.st.

Bourdon tube: AISI 316L st.st.

Case: stainless steel.

Ring: stainless steel, bayonet lock.

Window: glass.

Movement: stainless steel.

Dial: aluminium, white with black markings.

Pointer: not adjustable, aluminium, black.

01.18.1 - Standard Model, DS 2" (50mm)

Ambient temperature: -13...+149 °F (-25...+65 °C).

Protecti on degree: IP 55 as per EN 60529/IEC 529.

Case: stainless steel, crimped.

Ring: stainless steel, crimped.

Window: plastic.

Other features: as Standard Model, DS 1.5" (40mm).

01.18.2 - Fillable Model, DS 2" (50mm)

Protecti on degree: IP 67 as per EN 60529/IEC 529.

Other features: as Standard Model, DS 2" (50mm).

01.18.3 - Filled Model, DS 2" (50mm)

Damping liquid: glycerine 98%.

Ambient temperature: +32...+149 °F (0...+65 °C).

Process fluid temperature: max +149°F (+65 °C).

Protecti on degree: IP 67 as per IEC 529.

Other features: as Standard Model, DS 2" (50mm).

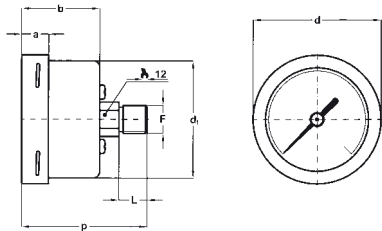

DS 1.5" (40mm)
D - BACK CONNECTION

Mounting	DS	F	a	b	c	d	d ₁	h	p	L	ch	Weight (1)
Lower	B 2" (50)	21M - G 1/4 A	0.15"	1.14"	0.43"	2.20"	2.00"	1.94" - 1.87"		0.59" - 0.51"	0.55"	0.20 lbs
		23M - 1/4-18 NPT	(4)	(29)	(11)	(56)	(51)	(49,5 - 47,5)		(15-13)	(14)	(0,095 kg)
Back	A 1.5" (40)	11M - G 1/8 A	0.37"	1.08"		1.77"	1.61"		1.73"	0.39"	0.47"	0.15 lbs
		13M - 1/8-27 NPT	(9,5)	(27,5)		(45)	(41)		(44)	(10)	(12)	(0,07 kg)
Back	B 2" (50)	11M - G 1/8 A	0.15"	1.14"		2.20"	2.00"		1.81"	0.39"	0.47"	0.17 lbs
		13M - 1/8-27 NPT	(4)	(29)		(56)	(51)		(46)	(10)	(12)	(0,078 kg)

dimensions : inches (mm)

(1) add 0.09 lbs (0,045 kg) when filled

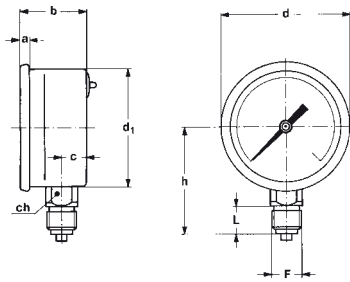

DS 2" (50mm)
A - LOWER CONNECTION

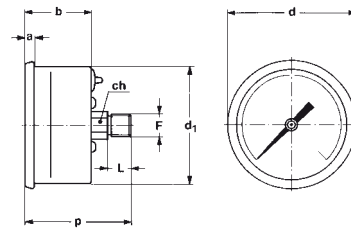

DS 2" (50mm)
D - BACK CONNECTION

OPTIONS

Diameters	DS 1.5" (40mm)	DS 2" (50mm)
B - "Ring"-clamp, for back connection pressure gauges		◆
E65 - IP 65 execution	◆	

"HOW TO ORDER" SEQUENCE

Section / Model / Case / Mounting / Diameter / Range / Process connection / Options
1 18 1 A A 11M B
2 D B 13M E65...T30
3 21M
23M

bourdon tube pressure gauge all stainless steel construction DS 2.5" (63mm)

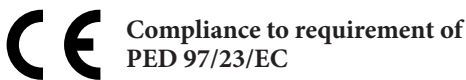

These instruments are built in conformity with the construction and safety S2 specifications of EN 837-1.

These instruments are designed for use in chemical and petrochemical processing industries, and in conventional power plants, to measure gaseous or liquid media which do not have high viscosity or do not cristalize. They are built to resist the most severe operating conditions created by the ambient environment and the process medium. For use on power units, pumps, hydro-cleaning machines, presses, engine compressors, turbines, diesel engines, chemical, petrochemical and refrigerating plants and on machines and equipment where pulsating pressures or mechanical vibrations are apparent, the liquid-filled version is recommended.

1.18.1 - Standard Model

Design: EN 837-1.

Safety designation: S1 as per EN 837-1.

Ranges: from 0...15 to 0...15000 psi; (from 0...1 to 0...1000 bar), (or other equivalent units).

Accuracy class: 1.6 as per EN 837-1.

Ambient temperature: -40...+149 °F (-40...+65 °C).

Process fluid temperature: max +212°F (+100 °C).

Thermal drift: ±0,4 %/10 °C of range (starting from 68°F - 20°C).

Working pressure:

75% of FSV for static pressure;

66% of FSV for pulsating pressure.

Over pressure limit (15 min max):

25% of FSV for pressure ranges ≤ 1500 psi (100 bar);

15% of FSV for pressure ranges 1500...9000 psi (100...600 bar);

10% of FSV for pressure ranges over 9000 psi (600 bar).

Protection degree: IP 55 as per EN 60529/IEC 529.

Socket material: AISI 316L st.st.

Bourdon tube: AISI 316L st.st.

Case: stainless steel.

Ring: stainless steel, bayonet lock.

Window: polycarbonate.

Movement: stainless steel.

Dial: plastic white with black markings.

Pointer: adjustable, aluminium, black.

1.18.2- Fillable Model

Safety designation: S2 as per EN 837-1.

Protection degree: IP 67 as per EN 60529/IEC 529.

Ring: stainless steel, crimped.

Pointer: not adjustable, aluminium, black.

Other features: as Standard Model.

1.18.3 - Filled Model

Safety designation: S2 as per EN 837-1.

Damping liquid: glycerine 98% or silicon oil.

Ambient temperature:

+32...+149 °F (0...+65 °C) with glycerine filling;

-4...+149 °F (-20...+65 °C) with glycerine filling mixture;

-40...+149 °F (-40...+65 °C) with silicon oil filling.

Process fluid temperature: max +149°F (+65 °C).

Protection degree: IP 67 as per EN 60529/IEC 529.

Ring: stainless steel, crimped.

Pointer: not adjustable, aluminium, black.

Other features: as Standard Model

bourdon tube pressure gauge
all stainless steel construction, DS 2.5" (63mm)

MGS18

RC8 - 00/13

IN ORDER TO IMPROVE THEIR PRODUCTION, MESSRS. NUOVA FIMA RESERVE THE RIGHT TO THEMSELVES TO MAKE ALL THE MODIFICATIONS THAT THEY DEEM INDISPENSABLE AT ANY TIME. UPDATED DATA-SHEETS ARE AVAILABLE ON SITE: www.nuovafima.com

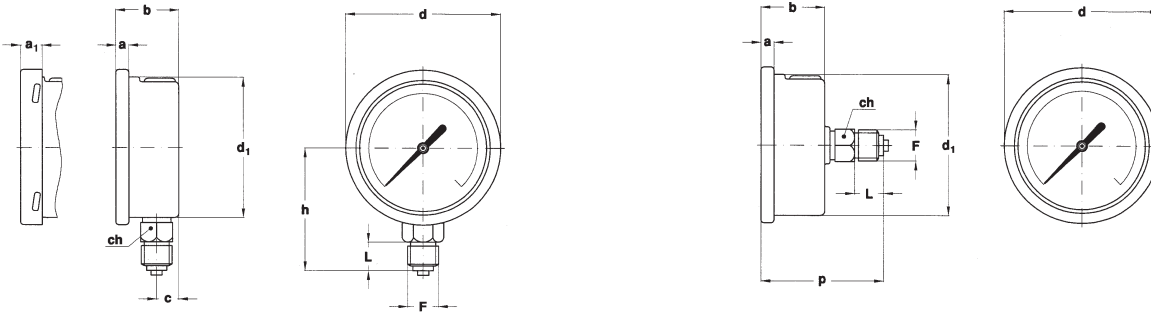

A - LOWER CONNECTION

D - BACK CONNECTION

Mounting	F	a	a ₁	b	c	d	d ₁	h	p	L	ch	Weight (1)
Lower	21M - G 1/4 A	0.22"	0.37"	1.10"	0.39"	2.67"	2.46"	2.13" - 2.17"		0.51"	0.55"	0.28 lbs
	23M - 1/4-18 NPT	(5,6)	(9,5)	(28)	(10)	(68)	(62,6)	(54,3 - 55,3)		(13)	(14)	(0,13 kg)
Back	21M - G 1/4 A	0.22"	0.37"	1.10"		2.67"	2.46"		2.11" - 2.15"	0.51"	0.55"	0.30 lbs
	23M - 1/4-18 NPT	(5,6)	(9,5)	(28)		(68)	(62,6)		(53,8 - 54,8)	(13)	(14)	(0,14 kg)

dimensions : inches (mm)

(1) add 0.15 lbs (0,07 kg) when filled

OPTIONS

Model	standard	fillable	filled
B - "U"-clamp, for back connection pressure gauges		◆	◆
C - Back flange, for lower connection pressure gauges	◆	◆	◆
E - Front flange, for back connection pressure gauges		◆	◆
P01 - Suitable for filling with silicone		◆	
S10 - Silicone filling			◆
G11 - Glycerine filling mixture			◆
T37 - Glass tempered window (1)	◆	◆	◆
T32 - Safety glass window	◆		

(1) Safety designation: S1 as per EN 837-1.

"HOW TO ORDER" SEQUENCE

Section / Model / Case / Mounting / Diameter / Range / Process connection / Options
1 18 1 A C 21M B, C, E
2 D 23M P01...T32
3



bourdon tube pressure gauges all stainless steel construction DS 4", 6" (100-150mm)

MGS18



PED 97/23/CE
ATEX 94/9/CE



ME 48
Gost R Pattern Approval



Chinese Pattern Approval

These instruments are designed for food, processing, pharmaceutical, petrochemical industries and for conventional and nuclear power plants. They are built to resist to the most severe conditions created by the process medium and by the environment and for those fluids, which have high viscosity and do not crystallize. The quality of the materials used to build the sensible element allows their use with high frequency pulsating pressures.

The TIG welding between the case and the process socket, strengthens the instrument and assures better containment of dampening fluid. The advantages of filling the case of the instrument with a dampening fluid are: reduced pointer fluctuation, reduced wear of rotating parts of the movement when pulsant vibrations and pulsations occur. Moreover condensation and corrosive atmospheres which could damage the internal parts are prevented.

1.18.1 - Standard Model

Design: EN837-1.

Safety designation: S1 as per EN 837-2.

Ranges: from 0...15 to 0...30000 psi (from 0...0,6 to 0...1600 bar or equivalent units).

Accuracy class: 1 as per EN 837-1.

Ambient temperature:

-40...+149 °F (-40...+65 °C), IP55 housing (IEC 529);

-58...+149 °F (-50...+65 °C), vented IP67 housing (IEC 529).

Process fluid temperature: -40...+302 °F (-40...+150 °C).

Thermal drift: ±0,4 % / 10 °C of range (starting from 68°F - 20°C).

Working pressure:

100% of FSV for static pressure;

90% of FSV for pulsating pressure.

Over pressure limit: 30% of FSV (max 12 hours).

Socket material: AISI 316L st.st.

Bourdon tube, seamless tube: AISI 316L st.st. for pressure ranges up to 20000 psi (0...1000 bar); Duplex st.st for range ≥ 20000 psi (0...1400 bar)

Case and ring: stainless steel.

Window: tempered glass.

Movement: stainless steel with internal limit stops for minimum and maximum pressure.

Dial: aluminium, white with black markings.

Pointer: adjustable, aluminium, black.

1.18.2 - Fillable Model

Ambient temperature: -40...+149 °F (-40...+65 °C), IP 67 housing (IEC 529).

Pointer: not adjustable, aluminium, black.

Other features: as Standard Model.

1.18.3 - Filled Model

Ranges: from 0...15 to 0...30000 psi (from 0...1 to 0...1600 bar or equivalent units).

Damping liquid: glycerine 98% or silicon oil.

Ambient temperature:

+32...+149 °F (0...+65 °C) with glycerine filling;

-4...+149 °F (-20...+65 °C) with glycerine filling mixture;

-40...+149 °F (-40...+65 °C) with silicon oil fluid filling.

Process fluid temperature: max +149°F (+65 °C).

Protection degree: IP 67 as per IEC 529.

Pointer: not adjustable, aluminium, black.

Other features: as Standard Model.

INSTRUMENTS FOR OXYGEN

To suit safety criteria of standard EN837-1/2, the pressure gauges for oxygen service must be solid-front type (with baffle wall and safety bursting back).

Pressure gauges suitable for this service are detailed on MGS20 DS 4", 6" (100-150 mm) sheet.



For use in potentially explosive atmospheres, instruments must be designed in conformity to ATEX 94/9/CE. This version is shown on separate data sheet available on request.

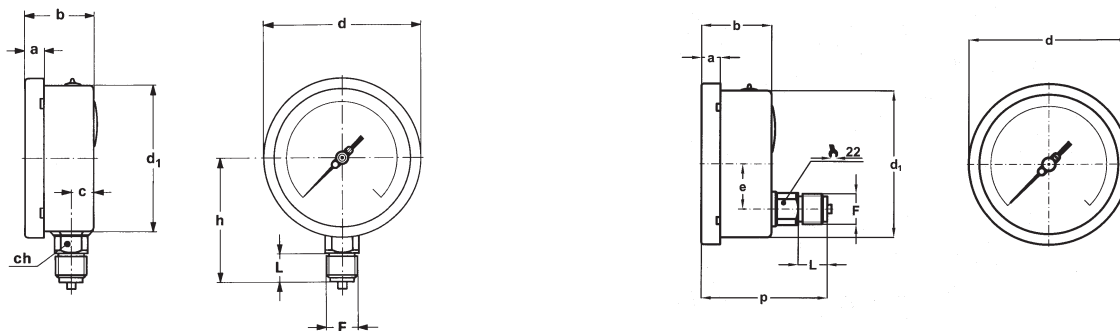

A - LOWER CONNECTION

D - BACK CONNECTION

Mounting	DS	F	a	b	c	d	d ₁	e	h	p	L	Weight (1)
Lower	E 4" (100)	41M - G 1/2 A 43M - 1/2-14 NPT	0.51" (13)	1.90" (48,5)	0.59" (15)	4.35" (110,6)	3.97" (101)		3.38" (86)		0.78" (20)	1.16 lbs (0,53 kg)
	G 6" (150)	41M - G 1/2 A 43M - 1/2-14 NPT	0.59" (15)	1.96" (50,5)	0.61" (15,5)	6.33" (161)	5.88" (149,6)		4.60 (117)		0.78" (20)	2.09 lbs (0,95 kg)
Back	E 4" (100)	41M - G 1/2 A 43M - 1/2-14 NPT	0.51" (13)	1.90" (48,5)		4.35" (110,6)	3.97" (101)	1.22" (31)		3.42" (87)	0.78" (20)	1.17 lbs (0,53 kg)
	G 6" (150)	41M - G 1/2 A 43M - 1/2-14 NPT	0.59" (15)	1.96" (50,5)		6.33" (161)	5.88" (149,6)	1.22" (31)		3.36" (85,5)	0.78" (20)	1.87 lbs (0,85 kg)

dimensions : inches (mm)

(1) add 0.72 lbs (0,33 kg) for DS 4" (100) and 1.65 lbs (0,78 kg) for DS 6" (150), when filled

OPTIONS

Model	standard	fillable	filled
B - "U"-clamp, for back connection pressure gauges	♦	♦	♦
C - Back flange, for lower connection pressure gauges	♦	♦	♦
E - Front flange, for back connection pressure gauges	♦	♦	♦
2G1 - ATEX II 2G c version	See the ATEX pressure gauges data-sheet for technical details		
2D1 - ATEX II 2GD c version			
C40 - AISI 316J st. case and ring	♦	♦	♦
K06 - Accuracy class 0,6 (1)	♦	♦	
L21 - Maximum pointer IP 44 on plexiglas window DS 4" (100 mm) (2)	♦		
L22 - Maximum pointer IP 65 on plexiglas window DS 4" (100 mm) (2)	♦	♦	♦
P01 - Suitable for filling with silicone		♦	
S10 - Silicone filling			♦
G11 - Glycerine filling mixture, DS 4" (100 mm)			♦
ECV -Vented housing version, Ambient temperature -50...+65 °C (3) (4)	♦		
E67 - Protection degree IP67 (5)	♦		
T01 - Tropicalization	♦	♦	♦
T32 - Safety glass window	♦	♦	♦

(1) For pressure ranges up to 6000 psi (400 bar). Not available for receivers.
(2) Accuracy refers to the area free from the maximum pointer action.

(3) to be ordered with E67 option
(4) not adjustable pointer
(5) to be ordered with ECV option

"HOW TO ORDER" SEQUENCE

Section	Model	Case	Mounting	Diameter	Range	Process connection	Options
1	18	1	A	E	41M	B, C, E	
		2	D	G	43M	2G1...T32	
		3					

bourdon tube pressure gauges
all stainless steel construction
ATEX versions,
DS 4", 6" (100-150mm)



Versions	
2G1	2D1
II	II
2	2
G	
	GD
TX	TX

Group: all the installations, with exclusion of mines
Category: high level of protection
Explosive atmosphere: inflammable gases
Explosive atmosphere: inflammable gases and dusts
Temperature classes: T1...T6, according to the process fluid temperature

These instruments are designed for explosive atmospheres in food, processing, pharmaceutical, petrochemical industries and conventional and nuclear power plants. The MGS pressure gauges are in conformity with the essential Health and Safety Requirements laid down in European Directive 94/9/EC for Group II, Category 2G or 2GD equipment in the T1...T6 temperature classes, as specified by EN 13463-1:2009 and EN 13463-5:2011 standards. They are NOT suitable for ZONES 0 and 20.

2G1 Version , Gas

4" and 6" (DS 100-150 mm) sizes are available, as **standard** version, or **fillable** version for pressure ranges ≤ 6 bar.

They keep the same functional and constructive features as MGS18-19-36 models. They differ from them as follows :

- Ambient temperature:** -4...+140 °F (-20...+60 °C).
- Max process fluid temperature:** see table (measured on the lowest point of socket).
- Protection degree:** IP 55 as per EN 60529/IEC 529.
- Windows:** high resistance safety glass.
- Socket:** with restrictor.
- Dial marking:** CE Ex II 2G c TX X, year of manufacture, model name and serial number.
- Special dial:** ranges different from standard, custom artworks and dials without Nuova Fima logo are not available.
- Options:** plexiglas or tempered glass windows are not available.
- Included documentation:** Installation manual.

2D1 Version , Gas and Dust

4" and 6" (DS 100-150 mm) are available, as **fillable** version for pressure ranges ≤ 6 bar, or **filled** version.

They keep the same functional and constructive features as MGS18-19-36 models. They differ from them as follows :

- Damping liquids:** glycerine 98%, silicon oil.
- Ambient temperature:** +32...+140 °F (+0...+60 °C) for glycerine filling; -4...+140 °F (-20...+60 °C) for silicon oil filling.
- Max process fluid temperature:** see table (measured on the lowest point of socket).
- Protection degree:** IP 65 as per EN 60529/IEC 529.
- Windows:** high resistance safety glass.
- Socket:** with restrictor.
- Dial marking:** CE Ex II 2GD c TX X, year of manufacture, model name and serial number.
- Special dial:** ranges different from standard, custom artworks and dials without Nuova Fima logo are not available.
- Options:** plexiglas or tempered glass windows are not available.
- Included documentation:** Installation manual.

Class	Instrument case	
	dry	filled
T6 : 185°F (85°C)	158°F (70°C)	149°F (65°C)
T5 : 212°F (100°C)	185°F (85°C)	
T4 : 275°F (135°C)	248°F (120°C)	
T3 : 392°F (200°C)	302°F (150°C)	
T2 : 572°F (300°C)		
T1 : 842°F (450°C)		

Technical File: TF1 - Rev. 1 - 21/03/08

bourdon tube "solid-front" pressure gauges all stainless steel construction DS 2.5" (63mm)

MGS20



These Solid-Front instruments are built in accordance with safety specifications of **EN 837-1 "S3"** and **ASME B40.1**. The safety construction consists of a solid separating wall in stainless steel, placed between the scale and the elastic element and a blow out back which is released from the case whenever an internal pressure, due to leaks, is created or the elastic element is broken. A leak tight fit is ensured if the instrument is filled with a dampening fluid to prevent damage due to vibration. These instruments are designed for use in chemical and petrochemical processing industries, and in conventional power plants. They are built to resist the most severe operating conditions created by the ambient environment and the process medium.

1.20.1 - Standard Model

Design: EN 837-1.

Safety designation: S3 as per EN 837-2.

Ranges: from 0...15 to 0...15000 psi; from 0...1 to 0...1000 bar (or other equivalent units)

Accuracy class: 1,6 as per EN 837-1.

Ambient temperature: -13...+149 °F (-25...+65 °C).

Process fluid temperature: max +212°F (+100 °C).

Thermal drift: ±0,4 % / 10 K of range (starting from 68°F - 20°C).

Working pressure:

75% of FSV for static pressure;

66% of FSV for pulsating pressure.

Over pressure limit (15 min max):

25% of FSV for pressure ranges ≤ 1500 psi (100 bar);

15% of FSV for pressure ranges over 1500 psi (100 bar).

Protection degree: IP 55 as per EN 60529/IEC 529.

Socket material: AISI 316L st.st.

Bourdon tube: AISI 316L st.st.

Case: stainless steel.

Ring: stainless steel, bayonet lock.

Blow out disk: plastic.

Window: safety glass.

Movement: stainless steel.

Dial: plastic.

Pointer: adjustable, aluminium, black.

1.20.2 - Fillable Model

Protection degree: IP 67 as per EN 60529/IEC 529.

Pointer: not adjustable, aluminium, black.

Other features: as Standard Model.

1.20.3 - Filled Model

Damping liquid: glycerine 98%, silicon oil or fluorinated fluid.

Ambient temperature:

+32...+149 °F (0...+65 °C) with glycerine filling;

-40...+149 °F (-40...+65 °C) with silicon oil filling;

-40...+149 °F (-40...+65 °C) with fluorinated fluid filling.

Process fluid temperature: max +149°F (+65 °C).

Protection degree: IP 67 as per EN 60529/IEC 529.

Pointer: not adjustable, aluminium, black.

Other features: as Standard Model.

INSTRUMENTS FOR OXYGEN

Glycerine or silicone should not be used with highly oxidizing agents such as oxygen, chlorine, nitric acid or hydrogen peroxide, because of danger of spontaneous chemical reaction, inflammability or explosion. The use of fluorinated fluid is recommended in these cases.

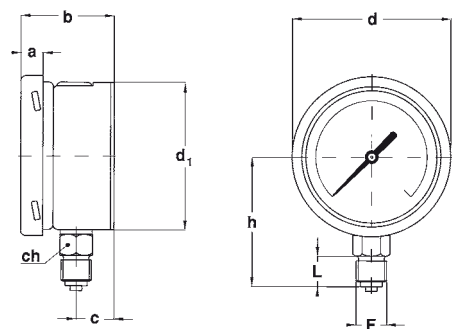

A - LOWER CONNECTION

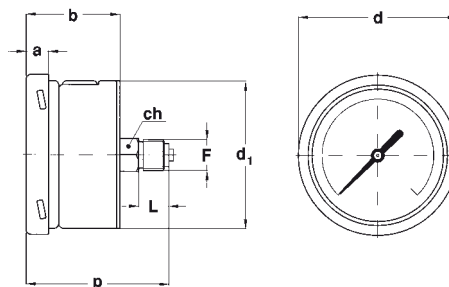

D - BACK CONNECTION

Mounting	F	a	b	c	d	d ₁	h	p	L	ch	Weight (1)
Lower	21M - G 1/4 A	0.39"	1.57"	0.65"	2.67"	2.46"	2.13" - 2.17"		0.51"	(0.55 x 0.31 - 0.55 x 0.35)	0.44 lbs
	23M - 1/4-18 NPT	(10)	(40)	(16,7)	(68)	(62,6)	(54,3 - 55,3)		(13)	(14 x 8 - 14 x 9)	(0,2 kg)
Back	21M - G 1/4 A	0.39"	1.57"		2.67"	2.46"		2.32" - 2.36"	0.51"	(0.55 x 0.31 - 0.55 x 0.35)	0.50 lbs
	23M - 1/4-18 NPT	(10)	(40)		(68)	(62,6)		(59,1 - 60,1)	(13)	(14 x 8 - 14 x 9)	(0,23 kg)

dimensions : inches (mm)

(1) add 0.22 lbs (0,1 kg) when filled

OPTIONS

Model	standard	fillable	filled
E - Front flange, for back connection pressure gauges	◆	◆	◆
P01 - Suitable for filling with silicone/Fluorinated fluid		◆	
P02 - Oxygen service	◆	◆ (2)	◆ (1)
S10 - Silicone filling			◆
F30 - Fluorinated fluid filling			◆

(1) to be ordered only with instruments filled of fluorinated fluid

(2) to be ordered with instruments suitable for fluorinated fluid filling

"HOW TO ORDER" SEQUENCE

Section / Model / Case / Mounting / Diameter / Range / Process connection / Options

1	20	1	A	C		21M	E
		2	D			23M	P01...F30
		3					

safety pressure gauges "solid-front"

all stainless steel construction

DS 4", 6" (100-150mm)

MGS20



CE PED 97/23/CE
ATEX 94/9/CE

PG ME 48
Gost R Pattern Approval

These instruments are built in conformity with the construction and safety specifications of **EN 837-1/S3** e **ASME B40.1**. In case of leaks or break of the elastic element, the operator is protected by a solid separating wall placed on the front of the instrument and by the blow out back. They are usually used in the chemical, petrochemical industries and in conventional and power plants. The TIG welding between the case and the process socket, strengthens the instrument and assures a better tight in case of dampening fluid. The advantages of filling the case of the instrument with a dampening fluid are: reduced pointer fluctuation, reduced wear of rotating parts of the movement when pulsant vibrations and pulsations occur. Moreover condensation and corrosive atmospheres which could damage the internal parts are prevented.

1.20.1 - Standard Model

Design: EN837-1.

Safety designation: S3 as per EN 837-2.

Ranges: from 0...15 to 0...30000 psi (from 0...0,6 to 0...1600 bar or equivalent units).

Accuracy class: 1 as per EN 837-1

Ambient temperature:

-40...+149 °F (-40...+65 °C), IP55 housing (EN 60529/IEC 529);

-58...+149 °F (-50...+65 °C), vented IP67 housing (EN 60529/IEC 529).

Process fluid temperature: -40...+302 °F (-40...+150 °C).

Thermal drift: ±0,4 % / 10 °C of range (starting from 68°F - 20°C).

Working pressure:

100% of FSV for static pressure;

90% of FSV for pulsating pressure.

Over pressure limit: 30% of FSV (max 12 hours).

Socket material: AISI 316L st.st.

Bourdon tube, seamless tube: AISI 316L st.st. for pressure ranges up to 20000 psi (0...1000 bar); Duplex st.st for range ≥ 20000 psi (0...1400 bar)

Case: stainless steel.

Ring: stainless steel, bayonet lock.

Blow out disk: stainless steel.

Window: safety glass.

Movement: stainless steel with internal limit stops.

Dial: aluminium, white with black markings.

1.20.2 - Fillable Model - Lower connection only

Ambient temperature: -40...+149 °F (-40...+65 °C), IP 67 housing (EN 60529/IEC 529).

Pointer: not adjustable, aluminium, black.

Other features: as Standard Model.

1.20.3 - Filled Model - Lower connection only

Ranges: from 0...15 to 0...30000 psi (from 0...1 to 0...1600 bar or equivalent units)

Damping liquid: glycerine 98%, silicon oil or fluorinated fluid.

Ambient temperature:

+32...+149 °F (0...+65 °C) with glycerine filling;

-40...+149 °F (-40...+65 °C) with silicon oil filling and fluorinated fluid filling.

Process fluid temperature: max +149°F (+65 °C).

Protection degree: IP 67 as per EN 60529/IEC 529.

Pointer: not adjustable, aluminium, black.

Other features: as Standard Model.

INSTRUMENTS FOR OXYGEN - Glycerine or silicone should not be used with highly oxidizing agents such as oxygen, chlorine, nitric acid or hydrogen peroxide, because of danger of spontaneous chemical reaction, inflammability or explosion. The use of fluorinated fluid is recommended in these cases.



For use in potentially explosive atmospheres, instruments must be designed in conformity to ATEX 94/9/CE. This version is shown on separate data sheet available on request.

safety pressure gauges "solid-front"
all stainless steel construction, DS4", 6" (100-150mm)

MGS20

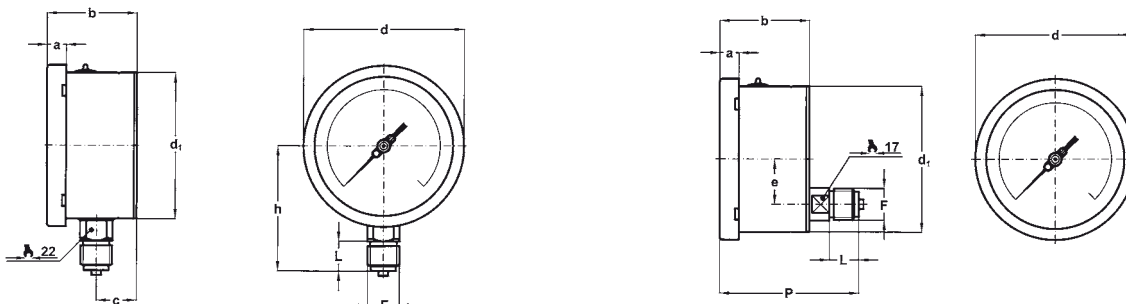

A - LOWER CONNECTION

D - BACK CONNECTION
- Standard model only

Mounting	DS	F	a	b	c	d	d ₁	e	h	p	L	Weight (1)
Lower	E 4" (100)	41M - G 1/2 A	0.51"	2.46"	1.16"	4.35"	3.97"		3.38"		0.78"	1.43 lbs
		43M - 1/2-14 NPT	(13)	(62,5)	(29,5)	(110,6)	(101)		(86)		(20)	(0,65 kg)
Lower	G 6" (150)	41M - G 1/2 A	0.59"	2.51"	1.18"	6.33"	5.92"		0.59"		0.78"	2.64 lbs
		43M - 1/2-14 NPT	(15)	(64)	(30)	(161)	(150,5)		(15)		(20)	(1,2 kg)
Back	E 4" (100)	41M - G 1/2 A	0.51"	2.46"		4.35"	3.97"	1.22"		3.75"	0.78"	1.54 lbs
		43M - 1/2-14 NPT	(13)	(62,5)		(110,6)	(101)	(31)		(95,5)	(20)	(0,70 kg)
Back	G 6" (150)	41M - G 1/2 A	0.59"	2.51"		6.33"	5.92"	1.22"		3.77"	0.78"	2.53 lbs
		43M - 1/2-14 NPT	(15)	(64)		(161)	(150,5)	(31)		(96)	(20)	(1,15 kg)

dimensions : inches (mm)

(1) add 0.95 lbs (0,43 kg) for DS 4" (100) and 1.76 lbs (0,8 kg) for DS 6" (150), when filled

OPTIONS

Model	standard	fillable	filled
C - Back flange, for lower connection pressure gauges	♦	♦	♦
E - Front flange, for back connection pressure gauges	♦		
2G1 -ATEX version II 2G c	<i>Constructive characteristics and ordering guide please refer to the relevant ATEX version data sheet.</i>		
2D1 -ATEX version II 2GD c			
C40 - AISI 316L st. case, ring and blow out disk	♦	♦	♦
K06 - Accuracy class: 0,6 as per EN 837-1 (1)	♦	♦	
P01 - Suitable for filling with silicon and fluorinated fluid		♦	
P02 - Oxygen service (4)	♦	♦ (2)	♦ (3)
P03 - Compensating device, for DS 4" (100 mm) only, lower mounting	♦	♦	♦
S10 - Silicone filling			♦
F30 - Fluorinated fluid filling			♦
ECV- Vented housing version, Ambient temperature -50...+65 °C (5) (6)	♦		
E67- Protection degree IP67 (7)	♦		
T01 - Tropicalization	♦	♦	♦

(1) For pressure ranges up to 6000 psi (400 bar). Not available for receivers.

(2) to be ordered with instruments suitable for fluorinated fluid filling

(3) to be ordered with fluorinated fluid filled instruments

(4) For pressure ranges up to 15000 psi (1000 bar)

(5) to be ordered with E67 option

(6) lower mounting and not adjustable pointer

(7) to be ordered with ECV option

"HOW TO ORDER" SEQUENCE

Section / Model / Case / Mounting / Diameter / Range / Process connection / Options

1 20 1 A E 41M C, E
2 D G 43M 2G1...T01
3

safety pressure gauges "solid-front"
all stainless steel ,construction
ATEX versions,
DS 4", 6" (100-150mm)

Versions	
2G1	2D1
II	II
2	2
G	
	GD
TX	TX

Group: all the installations, with exclusion of mines
Category: high level of protection
Explosive atmosphere: inflammable gases
Explosive atmosphere: inflammable gases and dusts
Temperature classes: T1...T6, according to the process fluid temperature



These instruments are designed for explosive atmospheres in food, processing, pharmaceutical, petrochemical industries and conventional and nuclear power plants. The MGS pressure gauges are in conformity with: to the essential Health and Safety Requirements laid down in European Directive 94/9/EC for Group II, Category 2G or 2GD equipment in the T1...T6 temperature classes, as specified by EN 13463-1:2009 and EN 13463-5:2011 standards; and to construction and safety specifications of EN 837-1/S3 e ASME B40.1. In case of leaks or break of the elastic element, the operator is protected by a solid separating wall placed on the front of the instrument and by the blow out back. They are NOT suitable for ZONES 0 and 20.

2G1 Version , Gas

4" and 6" (DS 100-150 mm) sizes are available, as **standard** version, or **fillable** version for pressure ranges ≤ 6 bar.

They keep the same functional and constructive features as MGS20-21-40 models. They differ from them as follows :

- Ambient temperature:** -4...+140 °F (-20...+60 °C).
- Max process fluid temperature:** see table (measured on the lowest point of socket).
- Protection degree:** IP 55 as per EN 60529/IEC 529.
- Windows:** high resistance safety glass.
- Socket:** with restrictor.
- Dial marking:** CE Ex II 2G c TX X, year of manufacture, model name and serial number.
- Special dial:** ranges different from standard, custom artworks and dials without Nuova Fima logo are not available.
- Options:** compensating devices, plexiglas or tempered glass windows are not available.
- Included documentation:** Installation manual.

Class	Instrument case	
	dry	filled
T6 : 185°F (85°C)	158°F (70°C)	149°F (65°C)
T5 : 212°F (100°C)	185°F (85°C)	
T4 : 275°F (135°C)	248°F (120°C)	
T3 : 392°F (200°C)		
T2 : 572°F (300°C)	302°F (150°C)	
T1 : 842°F (450°C)		

Technical File: TF1 - Rev. 1 - 21/03/08

2D1 Version , Gas and Dust

4" and 6" (DS 100-150 mm) are available, as **fillable** version for pressure ranges > 6 bar, or **filled** version, .

They keep the same functional and constructive features as MGS20-21-40 models. They differ from them as follows :

- Damping liquids:** glycerine 98%, silicon oil or fluorinated fluid.
- Ambient temperature:** +32...+140 °F (+0...+60 °C) for glycerine filling; -4...+140 °F (-20...+60 °C) for silicon oil or fluorinated fluid filling.
- Max process fluid temperature:** see table (measured on the lowest point of socket).
- Protection degree:** IP 65 as per EN 60529/IEC 529.
- Windows:** high resistance safety glass.
- Socket:** with restrictor.
- Dial marking:** CE Ex II 2GD c TX X, year of manufacture, model name and serial number.
- Special dial:** ranges different from standard, custom artworks and dials without Nuova Fima logo are not available.
- Options:** compensating devices, plexiglas or tempered glass windows are not available.
- Included documentation:** Installation manual.

bourdon tube pressure gauges HEAVY WORK DS 4", 6" (100-150mm)

MGS19



These instruments are designed for use in chemical and petrochemical processing industries, and in conventional power plants. They are built to resist the most severe operating conditions created by the ambient environment and the process medium. The high strength of the sensing element makes these instrument suitable to withstand high overpressure up to 4 times the full scale value and together with the case filling, they are suitable to high dynamic pulsating pressure. An Argonarc welded case/ socket strengthens the whole construction.

1.19.1 - Standard Model

Design: EN837-1.

Safety designation: S1 as per EN 837-2.

Ranges: from 0...15 to 0...10000 psi (from 0...1 to 0...600 bar or equivalent units).

Accuracy class: 1 according to EN 837-1.

Ambient temperature:

-40...+149 °F (-40...+65 °C), IP55 housing (EN 60529/IEC 529);

-58...+149 °F (-50...+65 °C), vented IP67 housing (EN 60529/IEC 529).

Process fluid temperature: -40...+302°F (-40...+150 °C).

Thermal drift: ±0,4 % / 10 °C of range (starting from 68°F- 20°C).

Working pressure :

100% of FSV for static pressures;

90% of FSV for pulsating pressures.

Overpressures: up to 400% of FSV (see tables at pag. 2)

Socket material: in AISI 316L.

Bourdon tube: in AISI 316L steamless tube.

Case: stainless steel.

Ring: stainless steel, bayonet lock.

Window: safety glass.

Movement: stainless steel with internal limit stops.

Dial: aluminium, white with black markings.

Pointer: adjustable, aluminium, black.

1.19.2 - Fillable Model

Ambient temperature: -40...+149 °F (-40...+65 °C), IP 67 housing (EN 60529/IEC 529).

Other features: as Standard Model.

1.19.3 - Filled Model

Accuracy Class: 1,6 as per EN 837-1.

Damping liquid: glycerine 98% or silicon oil.

Ambient temperature:

+32...+149°F (0...+65 °C) with glycerine filling;

-40...+149°F (-40...+65 °C) with silicon oil filling or fluorinated fluid filling.

Process fluid temperature: +149°F (+65 °C).

Protection degree: IP 67 as per EN 60529/IEC 529.

Other features: as Standard Model.

OXYGEN INSTRUMENTS

To suit criteria of standard EN837-1/2, the pressure gauges for oxygen service must be solid- front type (with baffle wall and safety bursting back).

Pressure gauges suitable for this service are detailed on MGS21 sheet.



For use in potentially explosive atmosphere, instruments must be designed in conformity to ATEX 94/9/CE. This version is shown in separate data sheet available on request.

bourdon tube pressure gauges

HEAVY WORK, DS 4", 6" (100-150mm)

MG519

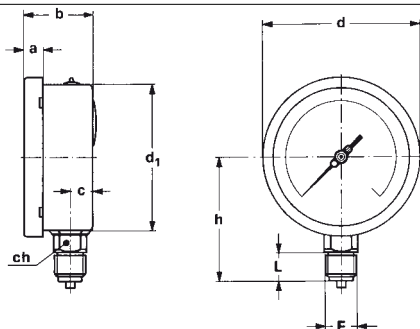

A - LOWER CONNECTION

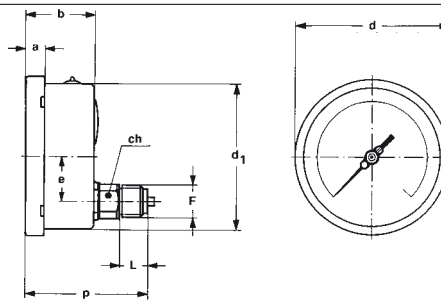

D - BACK CONNECTION

Mounting	DS	F	a	b	c	d	d ₁	e	h	p	L	ch	Weight (1)
Lower	E 4" (100)	41M - G 1/2 A	0.51"	1.90"	0.59"	4.35"	3.97"		3.38"		0.78"	0.87"	1.16 lbs
		43M - 1/2-14 NPT	(13)	(48,5)	(15)	(110,6)	(101)		(86)		(20)	(22)	(0,53 kg)
Lower	G 6" (150)	41M - G 1/2 A	0.59"	1.98"	0.61"	6.33"	5.88"		4.60"		0.78"	0.87"	2.24 lbs
		43M - 1/2-14 NPT	(15)	(50,5)	(15,5)	(161)	(149,6)		(117)		(20)	(22)	(1,02 kg)
Back	E 4" (100)	41M - G 1/2 A	0.51"	1.90"		4.35"	3.97"	1.22"		3.42"	0.78"	0.87"	1.14 lbs
		43M - 1/2-14 NPT	(13)	(48,5)		(110,6)	(101)	(31)		(87)	(20)	(22)	(0,52 kg)
Back	G 6" (150)	41M - G 1/2 A	0.59"	1.98"		6.33"	5.88"	1.22"		3.36"	0.78"	0.87"	2.09 lbs
		43M - 1/2-14 NPT	(15)	(50,5)		(161)	(149,6)	(31)		(85,5)	(20)	(22)	(0,95 kg)

dimensions : inches (mm)

(1) add 0.72 lbs (0,33 kg) for DS 4" (100) and 1.65 lbs (0,78 kg) for DS 6" (150), when filled

RANGES

bar (1)	Ranges	0...1	0...1,6	0...2,5	0...4	0...6	0...10	0...16	0...25	0...40	0...60	0...100	0...160	0...250	0...400	0...600
	Overpressure		4	6	10	16	25	40	48	75	80	120	200	320	500	800

psi	Ranges	0...15	0...30	0...60	0...100	0...160	0...200	0...300	0...400	0...600	0...1000	0...1500	0...2000	0...3000	0...4000	0...6000	0...10000
	Overpressure		60	120	240	400	480	600	900	1000	1200	2000	3000	4000	6000	8000	10000

bar (1)	Ranges	-1...0	-1...0,6	-1...1,5	-1...3	-1...5	-1...9	-1...15	-1...24
	Overpressure		3	5	9	15	23	39	47

psi	Ranges (2)	-30...0	-30...15	-30...30	-30...150
	Overpressure		45	100	125

(1) Available measurement units kPa, MPa, kg/cm²

(2) Vacuum measurement unit: InHg

OPTIONS

Model	standard	fillable	filled
B - "U"-clamp, for back connection pressure gauges	◆	◆	◆
C - Back flange, for lower connection pressure gauges	◆	◆	◆
E - Front flange, for back connection pressure gauges	◆	◆	◆
2G1 - ATEX II 2G c version	See the ATEX pressure gauges data-sheet for technical details		
2D1 - ATEX II 2GD c version			
C40 - AISI 316L st. st. case, ring and blow out disk	◆	◆	◆
P01 - Suitable for filling with silicone		◆	
S10 - Silicone filling			◆
ECV - Vented housing version, Ambient temperature -50...+65 °C (1) (2)			
E67 - Protection degree IP67 (3)	◆		
T01 - Tropicalization	◆	◆	◆

(1) to be ordered with E67 option

(3) to be ordered with ECV option

(2) not adjustable pointer

"HOW TO ORDER" SEQUENCE

Section / Model / Case / Mounting / Diameter / Range / Process connection / Options
1 19 1 A E 41M B, C, E
2 D G 43M 2G1...T01
3

bourdon tube "solid-front" pressure gauges

HEAVY WORK

DS 4", 6" (100-150mm)

MGS21



PED 97/23/CE
ATEX 94/9/CE

These instruments are designed for use in chemical and petrochemical processing industries, and in conventional power plants. They are built to resist the most severe operating conditions created by the ambient environment and the process medium. The high strength of the sensing element makes these instrument suitable to withstand high overpressure up to 4 times the full scale value and together with the case filling, they are suitable to high dynamic pulsating pressure. An Argonarc welded case/socket strengthens the whole construction. The **solid-front** version of these instruments is built in accordance with safety specifications of **EN 837-1** and **ASME B40.1**. The safety construction consists of a **solid separating wall** in stainless steel, placed between the dial and the elastic element and a **blow out back** which is released from the case whenever an internal pressure, due to leaks, is created or the elastic element is broken.

1.21.1 - Standard Model

Design: EN 837-1.

Safety designation: S3 as per EN 837-2.

Campi scala: from 0...15 to 10000 psi; (from 0...1 to 0...600 bar or other equivalent units)

Accuracy class: 1 as per EN 837-1.

Ambient temperature:

-40...+149 °F (-40...+65 °C), IP55 housing (EN 60529/IEC 529);

-58...+149 °F (-50...+65 °C), vented IP67 housing

(EN 60529/IEC 529).

Process fluid temperature: -40...+302°F (-40...+150 °C).

Thermal drift: ±0,4 % / 10 °C of range (starting from 68°F - 20°C).

Working pressure:

100% del FSV for static pressure;

90% del FSV for pulsating pressure.

Overpressure limit: 400% of FSV (see table at pag. 2)

Socket material: AISI 316L st.st.

Bourdon tube: AISI 316L st.st. steamless tube

Case: stainless steel.

Ring: stainless steel, bayonet lock.

Blow out disc: stainless steel.

Window: safety glass.

Movement: stainless steel with internal limit stop.

Dial: aluminium, white with black markings

Pointer: adjustable, aluminium, black.

1.21.2 - Fillable Model - Lower connection only

Ambient temperature: -40...+149 °F (-40...+65 °C), IP 67 housing (EN 60529/IEC 529).

Other features: as Standard Model.

1.21.3 - Filled Model - Lower connection only

Accuracy class: 1,6 as per EN 837-1.

Damping liquid: glycerine 98%, silicon oil or fluorinated fluid.

Ambient temperature:

+32...+149°F (0...+65 °C) with glycerine filling;

-40...+149°F (-40...+65 °C) with silicon oil filling or fluorinated fluid filling.

Process fluid temperature: max +149°F (+65 °C).

Protection degree: IP 67 as per EN 60529/IEC 529.

Window: tempered glass.

Other features: as Standard Model.

OXYGEN INSTRUMENTS

Glycerine and silicon oil should not be used with highly oxidizing agents as oxygen, chlorine, nitric acid or hydrogen peroxide because of danger of spontaneous chemical reaction, inflammability or explosion. The use of fluorinated fluid is recommended in these cases.



For use in potentially explosive atmospheres, instruments must be designed in conformity to ATEX 94/9/CE. This version is shown on separate data sheet available on request

bourdon tube "solid-front" pressure gauges HEAVY WORK, DS 4", 6" (100-150mm)

MGS21

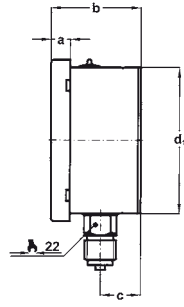

A - LOWER CONNECTION

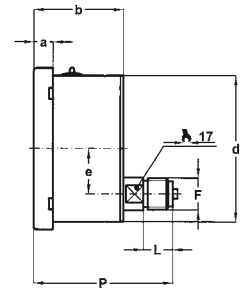
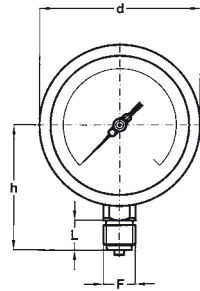

D - BACK CONNECTION



Mounting	DS	F	a	b	c	d	d ₁	e	h	p	L	Weight
Lower	4" (100)	E	41M - G 1/2 A	0.51"	2.46"	1.16"	4.35"	3.97"	3.38"		0.78"	1.43 lbs
		G	43M - 1/2-14 NPT	(13)	(62,5)	(29,5)	(110,6)	(101)	(86)		(20)	(0,65 kg)
Lower	6" (150)	E	41M - G 1/2 A	0.59"	2.51"	1.18"	6.33"	5.92"	4.60"		0.78"	2.64 lbs
		G	43M - 1/2-14 NPT	(15)	(64)	(30)	(161)	(150,5)	(117)		(20)	(1,2 kg)
Back	4" (100)	E	41M - G 1/2 A	0.51"	2.46"		4.35"	3.97"	1.22"	3.75"	0.78"	1.54 lbs
		G	43M - 1/2-14 NPT	(13)	(62,5)		(110,6)	(101)	(31)	(95,5)	(20)	(0,70 kg)
Back	6" (150)	E	41M - G 1/2 A	0.59"	2.51"		6.33"	5.92"	1.22"	3.77"	0.78"	2.53 lbs
		G	43M - 1/2-14 NPT	(15)	(64)		(161)	(150,5)	(31)	(96)	(20)	(1,15 kg)

dimensions : inches (mm)

(1) add 0.95 lbs (0,43 kg) for DS 4" (100) and 1.76 lbs (0,8 kg) for DS 6" (150), when filled

bar (l)	Ranges	0...1	0...1,6	0...2,5	0...4	0...6	0...10	0...16	0...25	0...40	0...60	0...100	0...160	0...250	0...400	0...600
	Overpressure		4	6	10	16	25	40	48	75	80	120	200	320	500	800

psi	Ranges	0...15	0...30	0...60	0...100	0...160	0...200	0...300	0...400	0...600	0...1000	0...1500	0...2000	0...3000	0...4000	0...6000	0...10000
	Overpressure		60	120	240	400	480	600	900	1000	1200	2000	3000	4000	6000	8000	10000

bar (l)	Ranges	-1...0	-1...0,6	-1...1,5	-1...3	-1...5	-1...9	-1...15	-1...24
	Overpressure		3	5	9	15	23	39	47

psi	Ranges (2)	-30...0	-30...15	-30...30	-30...150
	Overpressure		45	100	125

(1) Available measurement units kPa, MPa, kg/cm²

(2) Vacuum measurement unit: InHg

Model	standard	fillable	filled
C -Back flange, for lower connection pressure gauges	♦	♦	♦
E -Front flange, for back connection pressure gauges	♦		
2G1 -ATEX II 2G c version	See the ATEX pressure gauges data-sheet for technical details		
2D1 -ATEX II 2GD c version			
C40 -AISI 316L st. st. case, ring and blow out disc	♦	♦	♦
P01 -Suitable for filling with silicone/fluorinated fluid		♦	
P02 -Oxygen service	♦	♦ (1)	♦ (2)
P03 -Compensating device, for DS 4" (100 mm) and lower mounting only	♦	♦	♦
S10 -Silicone filling			♦
F30 -Fluorinated fluid filling			♦
ECV -Vented housing version, Ambient temperature -50...+65 °C (3) (4)	♦		
E67 -Protection degree IP67 (5)	♦		
T01 -Tropicalization	♦	♦	♦

(1) to be ordered with instruments suitable for fluorinated fluid filling

(2) to be ordered with fluorinated fluid filled instruments

(3) to be ordered with E67 option

(4) lower mounting and not adjustable pointer

(5) to be ordered with ECV option

"HOW TO ORDER" SEQUENCE

Section / Model / Case / Mounting / Diameter / Range / Process connection / Options

1 21 1 A E 41M C, E
2 D G 43M 2G1...T01
3

safety pressure gauges "solid-front"
all stainless steel construction
for high pressures,
DS 4", 6" (100-150mm)

MGS22



These instruments are built in conformity with the construction and safety specifications of **EN 837-1/S3 e ASME B40.1**. In case of leaks or break of the elastic element, the operator is protected by a solid separating wall placed on the front of the instrument and by the blow out back. They are mainly used on high pressure water jet technology like water cutting machines, hydro blasting pumps and turbines, hydrodemolition. The TIG welding between the case and the process socket, strengthens the instrument and assures a better tight in case of dampening fluid. The advantages of filling the case of the instrument with a dampening fluid are: reduced pointer fluctuation, reduced wear of rotating parts of the movement when pulsant vibrations and pulsations occur. Moreover condensation and corrosive atmospheres which could damage the internal parts are prevented.

1.22.1 - Standard Model

Design: S3 as per EN 837-2.
Ranges: 0...2500, 0...3000 and 0...4000 bar;
0...30000, 0...40000 and 0...60000 psi/bar.
Accuracy class: $\pm 1\%$ of F.S.V.
Ambient temperature: $-40...+149\text{ }^{\circ}\text{F}$ ($-40...+65\text{ }^{\circ}\text{C}$).
Process fluid temperature: $-40...+302\text{ }^{\circ}\text{F}$ ($-40...+150\text{ }^{\circ}\text{C}$).
Thermal drift: $\pm 0,4\%$ / $10\text{ }^{\circ}\text{C}$ of range (starting from 68°F - 20°C).
Working pressure:
75% of FSV for static pressure;
66% of FSV for pulsating pressure.
Over pressure limit: 10% of FSV (temporary).
Protection degree: IP 55 as per IEC 529.
Socket material: AISI 316L st.st.
Bourdon tube: duplex st.st. seamless tube.
Case: stainless steel.
Ring: stainless steel, bayonet lock.
Blow out disk: stainless steel.
Window: safety glass.
Movement: stainless steel with internal limit stops.
Dial: aluminium, white with black markings.
Pointer: adjustable, aluminium, black.

1.22.2 - Fillable Model

Protection degree: IP 67 as per IEC 529.
Pointer: not adjustable, aluminium, black.
Other features: as Standard Model.

1.22.3 - Filled Model

Damping liquid: glycerine 98%, silicon oil.
Ambient temperature:
 $+32...+149\text{ }^{\circ}\text{F}$ ($0...+65\text{ }^{\circ}\text{C}$) with glycerine filling;
 $-40...+149\text{ }^{\circ}\text{F}$ ($-40...+65\text{ }^{\circ}\text{C}$) with silicon oil filling.
Process fluid temperature: max $+149^{\circ}\text{F}$ ($+65\text{ }^{\circ}\text{C}$).
Protection degree: IP 67 as per IEC 529.
Pointer: not adjustable, aluminium, black.
Other features: as Standard Model.

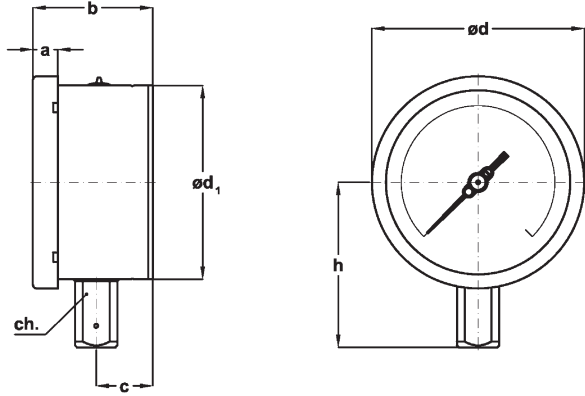

A - LOWER CONNECTION

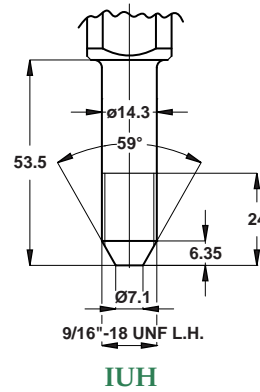
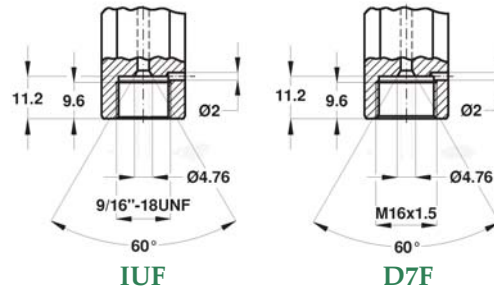

Mounting	DS	F	a	b	c	ø d	ø d ₁	h	ch	Weight (2)
Lower	E 4" (100)	IUF - 9/16-18 UNF-2B (1)	13	62	29,5	110,5	101	86	22	0,75 kg
		D7F - M16 x 1,5						120		
		IUH- 9/16-18 UNF-L.H.								
	G 6" (150)	IUF - 9/16-18 UNF-2B (1)	15	64	30	161	150,5	110	22	1,2 kg
D7F - M16 x 1,5		140								
IUH- 9/16-18 UNF-L.H.										

(1) suitable for following fittings:

- 1/4" F250C Autoclave
- 1/4" HF4 - HiP
- 1/4" Newport AMINCO HP
- 1/4" HP Butech

dimensions : mm

(2) add 0.95 lbs (0,43 kg) for DS 4" (100) and 1.76 lbs (0,8 kg) for DS 6" (150), when filled

OPTIONS

Model	standard	fillable	filled
C - Back flange, for lower connection pressure gauges	♦	♦	♦
C40 - AISI 316L st. st. case, blow out disk and ring	♦	♦	♦
P01 - Suitable for filling with silicon oil		♦	
S10 - Silicone filling			♦
T01 - Tropicalization	♦	♦	♦

"HOW TO ORDER" SEQUENCE

Section / Model/Case /Mounting/ Diameter / Range / Process connection / Options

1	22	1	A	E		D7F	C
		2		G		IUF	C40...T01
		3				IUH	

bourdon tube pressure gauges stainless steel construction DS 4" (100mm)

MGS44

- Laser calibration
- Free zero
- Fillable with glycerine "on site"
- Wetted parts in AISI 316L
- Safety plug



They are designed for industrial use. They are suitable for tough working conditions and for aggressive fluids. An exclusive Laser calibration procedure features each instrument and allows a very precise accuracy. Filling the case with dampening liquid prevents any condensation and the entrance of corrosive atmosphere increasing its resistance to vibrations and to pulsating pressures.

1.44.2 - Fillable Model

Design: EN 837-1.

Safety designation: S1 as per EN 837-2.

Ranges: from 0...15 to 0...6000 psi (from 0...1 to 0...400 bar or equivalent units).

Accuracy class: 1,6 as per EN 837-1.

Ambient temperature: -13...+149°F (-25...+65 °C).

Process fluid temperature: -13...+212 °F (-25...+100 °C).

Thermal drift: max ±0,4 % / 10 °C of scale range (starting from +68°F- 20°C).

Working pressure:

75% of FSV for static pressure.

66% of FSV for pulsating pressure.

Over pressure limit (15 min max):

25% of FSV for pressure ranges ≤ 1500 psi (100 bar);

15% of FSV for pressure ranges over 1500 psi (100 bar).

Protection degree: IP 67 as per IEC 529.

Socket material: AISI 316L st.st.

Elastic element: AISI 316L st.st.

Case: stainless steel

Ring: stainless steels, crimped

Window: tempered glass.

Movement: copper and stainless steel.

Dial: aluminium, white with black markings, or with double red and black markings.

Pointer: not adjustable, aluminium, black.

1.44.3 - Filled Model

Damping liquid: glycerine 98%, silicon oil.

Ambient temperature:

+32...+149 °F (0...+65 °C) with glycerine filling;

-40...+149 °F (-40...+65 °C) with silicon oil filling.

Process fluid temperature: max +149°F (+65 °C).

Other features: as fillable model.



For use in potentially explosive atmospheres, instruments must be designed in conformity to ATEX 94/9/CE. This version is shown on separate data sheet available on request.

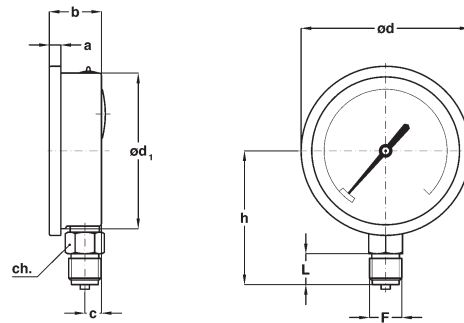

A - LOWER CONNECTION

F	a	b	c	Ø d	Ø d ₁	h	ch	L	Weight
41M - G 1/2 A	0.29"	1.34"	0.43"	4.33"	3.97"	3.43"	0.87"	0.78"	0.88 lbs (1)
43M - 1/2-14 NPT	(7,5)	(34)	(11)	(110)	(101)	(87)	(22)	(20)	(0,4 kg)

dimensions : inches (mm)

(1) Add 0.5 lbs (0,23 kg) when filled

OPTIONS

Model	fillable	filled
C - Back flange	♦	♦
2M1 - ATEX II 2G c IIA/B version (1)	≤ 6 bar	♦
2N1 - ATEX II 2GD c IIA/B version (1)	≥ 10 bar	♦
K10 - Accuracy class 1 as per EN 837-1.	1...400 bar	4...40 bar
M02 -Stainless steel movement	♦	♦
P01 - Suitable for filling with silicone	♦	
S10 - Silicone filling		♦
TPC -Polycarbonate window	♦	♦
V11 - St.st. restrictor 0,7 mm	♦	♦

(1) To be ordered with polycarbonate window only. Suitable for installation with IIA and IIB gas types only. See the ATEX pressure gauges data-sheet for technical details

“HOW TO ORDER” SEQUENCE

Section / Model / Case / Mounting / Diameter / Range / Process connection / Options
1 44 2 A E 41M C
3 43M 2M1...V11

bourdon tube pressure gauges

NACE MR0103/MR0175 - ISO 15156-3 version

DS 4", 6" (100-150mm)

MGS36



These instruments are designed for petrochemical industry. They are built to resist to the most severe conditions created by H₂S, by the environment and for those fluids, which have high viscosity and do not crystallize. The quality of the materials used to build the sensible element allows their use with high frequency pulsating pressures. The TIG welding between the case and the process socket, strengthens the instrument and assures a better tight in case of dampening fluid. The advantages of filling the case of the instrument with a dampening fluid are: reduced pointer fluctuation, reduced wear of rotating parts of the movement when pulsant vibrations and pulsations occur. Moreover condensation and corrosive atmospheres which could damage the internal

1.36.1 - Standard Model

Design: EN 837-1, ISO 15156-3.

Safety designation: S1 as per EN 837-2.

Ranges: from 0...15 to 0...10000 psi (from 0...1 to 0...600 bar or equivalent units).

Accuracy class: 1 as per EN 837-1.

Ambient temperature:

-40...+149 °F (-40...+65 °C), IP55 housing (EN 60529/IEC 529);

-58...+149 °F (-50...+65 °C), vented IP67 housing

(EN 60529/IEC 529).

Process fluid temperature: -40...+302 °F (-40...+150 °C).

Thermal drift: ±0,4 % / 10 °C of range (starting from 68°F - 20°C).

Working pressure:

100% of FSV for static pressure;

90% of FSV for pulsating pressure.

Over pressure limit: 30% of FSV (max 12 hours).

Socket material: AISI 316L st.st. or Monel 400.

Bourdon tube: Monel 400 seamless tube.

Leak test: Helium Test leak Search (max 1x10⁻⁶ mbar x l x s⁻¹)

Case: stainless steel.

Ring: stainless steel, bayonet lock.

Window: tempered glass.

Movement: stainless steel with internal limit stops.

Dial: aluminium, white with black markings.

Pointer: adjustable, aluminium, black.

1.36.2 - Fillable Model

Ambient temperature: -40...+149 °F (-40...+65 °C), IP 67 housing (EN 60529/IEC 529).

Other features: as Standard Model.

1.36.3 - Filled Model

Dampening liquid: glycerine 98% or silicon oil.

Ambient temperature:

+32...+149 °F (0...+65 °C) with glycerine filling;

-4...+149 °F (-20...+65 °C) with glycerine filling mixture;

-40...+149 °F (-40...+65 °C) with silicon oil fluid filling.

Process fluid temperature: max +149°F (+65 °C).

Protection degree: IP 67 as per EN 60529/IEC 529.

Other features: as Standard Model.



For use in potentially explosive atmospheres, instruments must be designed in conformity to ATEX 94/9/CE. This version is shown on separate data sheet available on request.

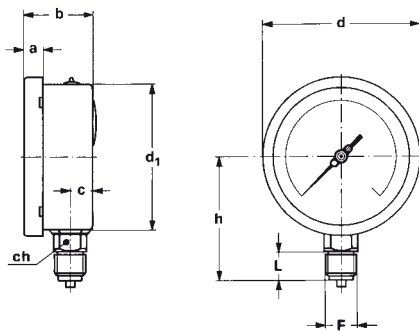

A - LOWER CONNECTION

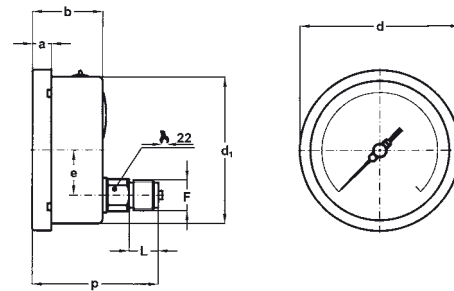

D - BACK CONNECTION

Mounting	DS	F	a	b	c	d	d1	e	h	p	L	Weight (1)	
Lower	4" (100)	E	41M - G 1/2 A	0.51"	1.90"	0.59"	4.35"	3.97"		3.38"	0.78"	1.16 lbs	
		43M - 1/2-14 NPT	(13)	(48,5)	(15)	(110,6)	(101)	(86)	(20)	(0,53 kg)			
	6" (150)	G	41M - G 1/2 A	0.59"	1.98"	0.61"	6.33"	5.88"		4.60"	0.78"	2.24 lbs	
		43M - 1/2-14 NPT	(15)	(50,5)	(15,5)	(161)	(149,6)	(117)	(20)	(1,02 kg)			
Back	4" (100)	E	41M - G 1/2 A	0.51"	1.90"		4.35"	3.97"	1.22"		3.42"	0.78"	1.14 lbs
		43M - 1/2-14 NPT	(13)	(48,5)		(110,6)	(101)	(31)	(87)	(20)	(0,52 kg)		
	6" (150)	G	41M - G 1/2 A	0.59"	1.98"		6.33"	5.88"	1.22"		3.36"	0.78"	2.09 lbs
		43M - 1/2-14 NPT	(15)	(50,5)		(161)	(149,6)	(31)	(85,5)	(20)	(0,95 kg)		

dimensions : inches (mm)

(1) add 0.72 lbs (0,33 kg) for DS 4" (100) and 1.65 lbs (0,78 kg) for DS 6" (150), when filled

OPTIONS

Model	standard	fillable	filled
B - "U"-clamp, for back connection pressure gauges	♦	♦	♦
C - Back flange, for lower connection pressure gauges	♦	♦	♦
E - Front flange, for back connection pressure gauges	♦	♦	♦
2G1 - ATEX II 2G c version	See the ATEX pressure gauges data-sheet for technical details		
2D1 - ATEX II 2GD c version			
C40 - AISI 316L st. st. case and ring	♦	♦	♦
E07 - Socket material MONEL 400	♦	♦	♦
E30 - NACE MR0103/MR0175 -ISO15156-3 certificate	♦	♦	♦
P01 - Suitable for filling with silicone		♦	
G11 - Glycerine filling mixture, DS 4" (100 mm)			♦
ECV - Vented housing version, Ambient temperature -50...+65 °C (1) (2)	♦		
E67 - Protection degree IP67 (3)	♦		
S10 - Silicone filling			♦
T01 - Tropicalization	♦	♦	♦
T32 - Safety glass window	♦	♦	♦

(1) to be ordered with E67 option

(2) not adjustable pointer

(3) to be ordered with ECV option

"HOW TO ORDER" SEQUENCE

Section / Model / Case / Mounting / Diameter / Special version / Range / Process connection / Options

1 **36** **1** **A** **E** **---** **41M** **B...E**
 2 **D** **G** **E07** **43M** **2G1...T32**
 3

bourdon tube "solid-front" pressure gauges NACE MR0103/MR0175 - ISO 15156-3 version DS 4", 6" (100-150mm)

MGS40



These instruments are built in conformity with the construction and safety specifications of EN 837-1/S3 e ASME B40.1. In case of leaks or break of the elastic element, the operator is protected by a solid separating wall placed on the front of the instrument and by the blow out back. They are usually used in the petrochemical and natural gas industry; they are built to resist to the most severe conditions created by H₂S, by the environment and for those fluids, which have high viscosity and do not crystallize. The TIG welding between the case and the process socket, strengthens the instrument and assures a better tight in case of dampening fluid. The advantages of filling the case of the instrument with a dampening fluid are: reduced pointer fluctuation, reduced wear of rotating parts of the movement when pulsant vibrations and pulsations occur. Moreover condensation and corrosive atmospheres which could damage the internal parts.

1.40.1 - Standard Model

Design: EN 837-1, ISO 15156-3.

Safety designation: S3 as per EN 837-2.

Ranges: from 0...15 to 0...10000 psi ; (from 0...1 to 0...600 bar or other equivalent units).

Accuracy class: 1 as per EN 837-1.

Ambient temperature:

-40...+149 °F (-40...+65 °C), IP55 housing (EN 60529/IEC 529);

-58...+149 °F (-50...+65 °C), vented IP67 housing

(EN 60529/IEC 529).

Process fluid temperature: -40...+302°F (-40...+150 °C).

Thermal drift: ±0,4 % / 10 °C of range (starting from 68°F - 20°C).

Working pressure:

100% of FSV for static pressure;

90% of FSV for pulsating pressure.

Overpressure: 30% of FSV (max 12 h).

Socket material: AISI 316L or MONEL 400.

Bourdon tube: MONEL 400 seamless tube

Leak test: Helium Test leak search, (max 1x10⁻⁶ mbar x l x s⁻¹).

Case: stainless steel

Ring: stainless steel, bayonet lock.

Blow out disk: stainless steel.

Window: safety glass.

Movement: stainless steel with internal limit stops.

Dial: aluminium, white with black markings.

1.40.2 - Fillable Model - Lower connection only

Ambient temperature: -40...+149 °F (-40...+65 °C), IP 67 housing (EN 60529/IEC 529).

Other features: as Standard Model.

1.40.3 - Filled Model - Lower connection only

Filling liquid: glycerina 98%, silicon oil or Fluorinated fluid.

Ambient temperature:

+32...+149°F (0...+65 °C) with glycerine filling;

-40...+149°F (-40...+65 °C) with silicon oil filling or fluorinated fluid filling.

Process fluid temperature: +149°F (+65 °C).

Protection degree: IP 67 as per EN 60529/IEC 529.

Other features: as Standard Model



For use in potentially explosive atmospheres, instruments must be designed in conformity to ATEX 94/9/CE. This version is shown on separate data sheet available on request.

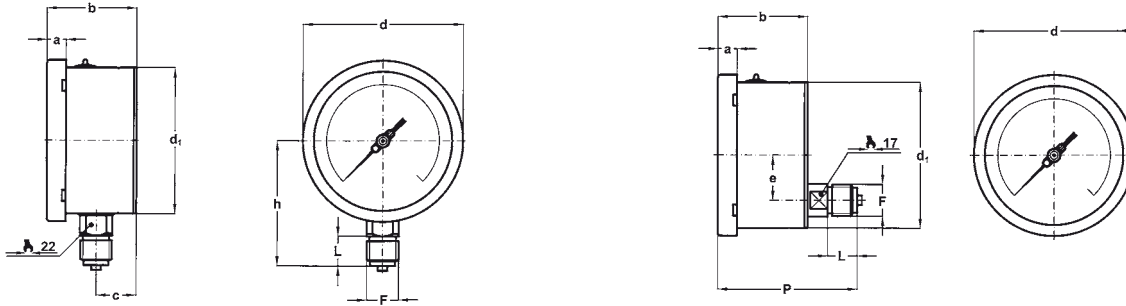

A - LOWER CONNECTION

**D - BACK CONNECTION,
Standard model only**

Mounting	DS	F	a	b	c	d	d ₁	e	h	p	L	Weight (1)
Lower	E 4" (100)	41M - G 1/2 A	0.51"	2.46"	1.16"	4.35"	3.97"		3.38"		0.78"	1.43 lbs (1)
		43M - 1/2-14 NPT	(13)	(62,5)	(29,5)	(110,6)	(101)		(86)		(20)	(0,65 kg)
Lower	G 6" (150)	41M - G 1/2 A	0.59"	2.51"	1.18"	6.33"	5.92"		4.60"		0.78"	2.64 lbs (1)
		43M - 1/2-14 NPT	(15)	(64)	(30)	(161)	(150,5)		(117)		(20)	(1,2 kg)
Back	E 4" (100)	41M - G 1/2 A	0.51"	2.46"		4.35"	3.97"	1.22"		3.75"	0.78"	1.54 lbs
		43M - 1/2-14 NPT	(13)	(62,5)		(110,6)	(101)	(31)		(95,5)	(20)	(0,70 kg)
Back	G 6" (150)	41M - G 1/2 A	0.59"	2.51"		6.33"	5.92"	1.22"		3.77"	0.78"	2.53 lbs
		43M - 1/2-14 NPT	(13)	(64)		(161)	(150,5)	(31)		(96)	(20)	(1,15 kg)

dimensions : inches (mm)

(1) add 0.73 lbs (0,33 kg) for DS 4" (100) and 1.76 lbs (0,8 kg) for DS 6" (150), when filled

OPTIONS

Model	standard	fillable	filled
C - Back flange, for lower connection pressure gauges	◆	◆	◆
E - Front flange, for back connection pressure gauges	◆		
2G1 - ATEX II 2G c version	See the ATEX pressure gauges data-sheet for technical details		
2D1 - ATEX II 2GD c version			
C40 - AISI 316L st. st. case, ring and blow out disk	◆	◆	◆
E07 - Socket material MONEL 400	◆	◆	◆
E30 - NACE MR0103/MR0175 - ISO 15156-3 certificate	◆	◆	◆
F30 - Fluorinated fluid filling			◆
P01 - Suitable for filling with silicone/Fluorinated fluid		◆	
P03 - Compensating device, for DS 4" (100 mm) and lower mounting only	◆	◆	◆
S10 - Silicone filling			◆
ECV -Vented housing version, Ambient temperature -50...+65 °C (1) (2)	◆		
E67 - Protection degree IP67 (3)	◆		
T01 - Tropicalization	◆	◆	◆

(1) to be ordered with E67 option

(2) lower mounting and not adjustable pointer

(3) to be ordered with ECV option

"HOW TO ORDER" SEQUENCE

Section / Model / Case / Mounting / Diameter / Special version /Range / Process connection / Options

1 40 1 A E -- 41M C...E
2 D G E07 43M 2G1...T01
3

bourdon tube "solid-front" pressure gauges NACE MR0103/MR0175 -ISO 15156-3 version turret case - DS 4.5" (125mm)

MGS60



These instruments are built in conformity with the construction and safety specifications of **ASME B40.1**.

In case of leaks or break of the elastic element the operator is protected by a stainless steel safety cell solid front and by the blow-out back. They are usually used in the petrochemical industry. They are built to resist to the most severe conditions created by H₂S, by the environment and for those fluids which have high viscosity and do not crystallize. The TIG welding between the safety cell and the process socket strengthens the instrument and assures a better tight in case of dampening fluid. The advantages of filling the case of the instrument with a dampening fluid are: reduced pointer fluctuation, reduced wear of rotating parts of the movement when pulsant vibrations and pulsations occur. Moreover condensation and corrosive atmospheres which could damage the internal parts.

1.60.2 - Fillable Model - Lower connection only

Design: ASME B40.1, ISO 15156-3.

Ranges: from 0...15 to 0...10000 psi (from 0...1 to 0...600 bar or equivalent units).

Accuracy: 1A Grade as per ASME B40.1 (± 1 % of FSV).

Ambient temperature: -13...+149°F (-25...+65°C).

Process fluid temperature: -22...+302°F (-30...+150°C max).

Thermal drift: $\pm 0,4$ % / 10 K of range (starting from 68°F - 20°C).

Working pressure:

100% of FSV for static pressure;

90% of FSV for pulsating pressure.

Overpressure limit: 30% of FSV (max 12 h).

Protection degree: IP 65 as per EN 60529/IEC 529.

Socket material: AISI 316L st.st. or MONEL 400

Bourdon tube: MONEL 400 seamless tube.

Leak test: Helium Test leak search

(max 1×10^{-6} mbar $\times 1 \times s^{-1}$).

Case and blow out disk: strengthened polyammides, fiber glass, UV rays stabilized.

Ring: strengthened polypropylene fiber glass.

Safety cell: stainless steel.

Window: tempered glass.

Movement: stainless steel with internal limit stops for minimum and maximum pressure.

Dial: aluminium, white with black markings.

Pointer: adjustable, aluminium, black.

1.60.3 - Filled Model - Lower connection only

Filling liquid: glycerine 98%, silicon oil or Fluorinated fluid.

Ambient temperature:

+32...149°F (0...+65 °C) with glycerine filling;

-40...+149°F (-40...+65 °C) with silicon oil filling;

-40...+149°F (-40...+65 °C) with fluorinated fluid filling.

Fluid process temperature: +149°F (+65 °C).

Protection degree: IP 67 as per EN 60529/IEC 529.

Compensating device: gum.

Other features: as fillable model.

1.60.1 - Standard Model - Back connection only

Protection degree: IP 55 as per EN 60529/IEC 529.

Case: phenolic resin.

Ring and blow out disk: strengthened polyammides, fiber glass.

Safety cell: not available.

Separating wall: phenolic resin.

Other features: as fillable model.

bourdon tube "solid-front" pressure gauges
NACE MR0103/MR0175 - ISO 15156-3 version,
turret case DS 4.5" (125mm)

MGS60

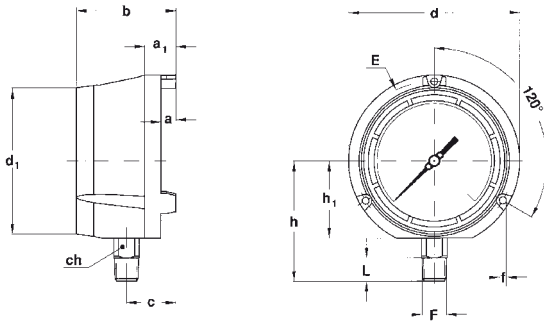

A - LOWER CONNECTION

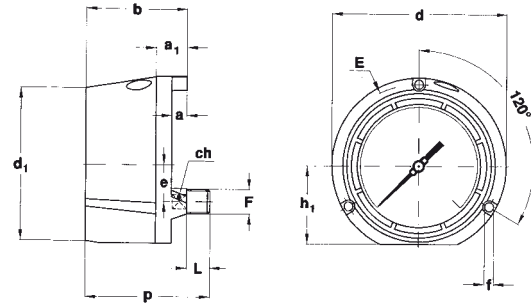

**D - BACK CONNECTION,
FOR STANDARD MODEL ONLY**

Mounting	F	a	a ₁	b	c	d	d ₁	e	E	f	h	h ₁	p	ch	L	Weight (1)
Lower	43M 1/2-14 NPT	0.51" (13)	1.06" (27)	3.38" (86)	1.65" (42)	5.82" (148)	4.96" (126)		5.39" (137)	0.25" (6,5)	4.07" (103,5)	2.61" (66,5)		0.86" (22)	0.78" (20)	1.78 lbs (0,81 kg)
Back	43M 1/2-14 NPT	0.51" (13)	1.06" (27)	3.38" (86)		5.82" (148)	5.07" (129)	1.22" (31)	5.39" (137)	0.23" (6)	4.07" (103,5)	2.61" (66,5)	4.17" (106)	0.66" (17)	0.78" (20)	1.78 lbs (0,81 kg)

dimensions : inches (mm)

(1) add 1.10 lbs (0,5 kg) when filled

OPTIONS

Model	standard	fillable	filled
E07 - Socket material MONEL 400	◆	◆	◆
E30 - NACE MR0103/MR0175 - ISO 15156-3 certificate	◆	◆	◆
F11 - Panel mounting kit	◆	◆	◆
F30 - Fluorinated fluid filling			◆
P01 - Suitable for filling with silicone/fluid filling		◆	
P03 - Blow out disk with compensating device		◆	
S10 - Silicone filling			◆
T01 - Tropicalization	◆	◆	◆
T32 - Safety glass window	◆	◆	◆

"HOW TO ORDER" SEQUENCE

Section / Model / Case / Mounting / Diameter / Special version / Range / Process connection / Options
1 60 1 A F --- 41M E30...T32
2 D E07
3

bourdon tube pressure gauges

NACE MR0175/ISO15156-3 version

DS 4", 6" (100-150mm)

MGS37



PED 97/23/CE
ATEX 94/9/CE

These instruments are designed for petrochemical industry. They are built to resist to the most severe conditions created by H₂S and by the environment. The quality of the materials used to build the sensible element allows their use with high frequency pulsating pressures. The TIG welding between the case and the process socket, strengthens the instrument and assures a better tight in case of dampening fluid. The advantages of filling the case of the instrument with a dampening fluid are: reduced pointer fluctuation, reduced wear of rotating parts of the movement when pulsant vibrations and pulsations occur. Moreover condensation and corrosive atmospheres which could damage the internal

1.37.1 - Standard Model

Design: EN 837-1.

Safety designation: S1 as per EN 837-2.

Ranges: from -30...0 INHG to 0...6000 psi
(from -1...0 to 0...400 bar or equivalent units).

Accuracy class: 1 as per EN 837-1.

Ambient temperature: -13...+149 °F (-25...+65 °C).

Process fluid temperature: -40...+212 °F (-40...+100 °C).

Working pressure:

100% of FSV for static pressure;

90% of FSV for pulsating pressure.

Over pressure limit:

30% of FSV, max 6500 psi - 450 bar (max 12 hours).

Special overpressure (upon request):

1000 psi (60 bar) for pressure > 15 psi (1 bar) ... ≤ 150 psi (10 bar);

3500 psi (250 bar) for pressure > 150 psi (10 bar) ... ≤ 1500 psi (100 bar);

6500 psi (450 bar) for pressure > 1500 psi (100 bar) ... ≤ 6000 psi (400 bar).

Protection degree: IP 55 as per EN 60529/IEC 529.

Bourdon tube: AISI 316L st.st.

Diaphragm seal filling fluid: silicone oil.

Wetted parts: Hastelloy C276.

Leak test: Helium Test leak Search (max 1x10⁻⁶ mbar x l x s⁻¹)

Case: stainless steel.

Ring: stainless steel, bayonet lock.

Window: tempered glass.

Movement: stainless steel with internal limit stops for minimum and maximum pressure.

Dial: aluminium, white with black markings.

Pointer: adjustable, aluminium, black.

1.37.2 - Fillable Model

Protection degree: IP 67 as per EN 60529/IEC 529.

Other features: as Standard Model.

1.37.3 - Filled Model

Pressure gauges damping liquid:

glycerine 98%, silicon oil or fluorinated fluid.

Ambient temperature:

+32...+149 °F (0...+65 °C) with glycerine filling;

-40...+149 °F (-40...+65 °C) with silicon oil filling;

-40...+149 °F (-40...+65 °C) with fluorinated fluid filling.

Process fluid temperature: max +212°F (+100 °C).

Protection degree: IP 67 as per EN 60529/IEC 529.

Other features: as Standard Model.

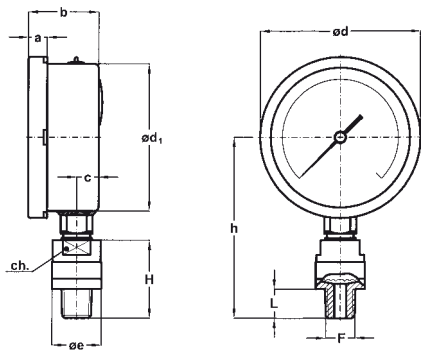

A - LOWER CONNECTION

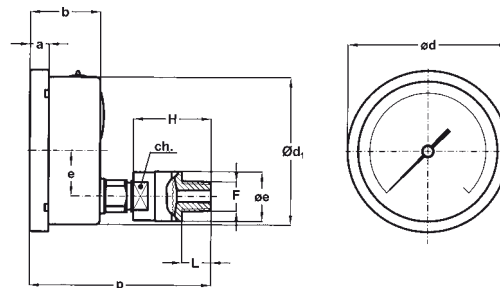

D - BACK CONNECTION

DS	Ranges	F	a	b	c	ø d	ø d ₁	e	øe	h	H	L	p	ch	Weight (1)
E 4" (100)	≤ 160 psi (≤ 10 bar)	43M 1/2-14 NPT	0.51"	1.91"	0.59"	4.35"	3.97"	1.22"	2.24"	4.86"	2.12"	0.78"	4.94"	1.06"	2.18 lbs (0,99 kg)
	> 160 psi (> 10 bar)		(13)	(48,5)	(15)	(110,6)	(101)	(31)	1.34"						
G 6" (150)	≤ 160 psi (≤ 10 bar)	43M 1/2-14 NPT	0.59"	1.99"	0.61"	6.33"	5.88"	1.22"	2.24"	6.12"	(54)	(20)	4.88"	(27)	3.26 lbs (1,48 kg)
	> 160 psi (> 10 bar)		(15)	(50,5)	(15,5)	(161)	(149,6)	(31)	1.34"						

dimensions : mm

(1) add 0.72 lbs (0,33 kg) for DS 4" (100) and 1.65 lbs (0,75 kg) for DS 6" (150), when filled

OPTIONS

Model	standard	fillable	filled
E - Front flange, for back connection pressure gauges	♦	♦	♦
2G1 - ATEX II 2G c version	<i>See the ATEX pressure gauges data-sheet for technical details</i>		
2D1 - ATEX II 2GD c version			
C40 - AISI 316L case and ring	♦	♦	♦
E75 - NACE MR0175/ISO 15156-3 certificate	♦	♦	♦
P02 - Oxygen service	♦	♦ (1)	♦ (2)
P01 - Suitable for filling with silicone / fluorinated fluid		♦	
S10 - Silicone filling			♦
F30 - Fluorinated fluid filling			♦
SPS - Special overpressure	♦	♦	♦
T01 - Tropicalization	♦	♦	♦
T32 - Safety glass window	♦	♦	♦

(1) to be ordered with instruments suitable for fluorinated fluid filling

(2) to be ordered with fluorinated fluid filled instruments

"HOW TO ORDER" SEQUENCE

Section / Model / Case / Mounting / Diameter / Range / Process connection / Options

1 **37** **1** **A** **E** **43M** **E**
 2 **D** **G** **2G1...2D1**
 3 **C40...T32**

bourdon tube pressure gauges

ATEX, NACE MATEX, NACE MR 01.75 / ISO 15156

TEX, NACE MR 01.75 / ISO 15156 01.75 / ISO 15156

DS 4", 6" (100-150mm)

MGS37

RB0 - 09/09



Versions	
2G1	2D1
II	II
2	2
G	
	GD
T6	T6

Group: all the installations, with exclusion of mines

Category: high level of protection

Explosive atmosphere: inflammable gases

Explosive atmosphere: inflammable gases and dusts

Temperature class: 85°C

These instruments are designed for petrochemical industry. They are built to resist to the most severe conditions created by H₂S and by the environment. The MGS pressure gauges are in conformity with the essential Health and Safety Requirements laid down in European Directive 94/9/EC for Group II, Category 2G or 2GD equipment in the T1...T6 temperature classes. They are NOT suitable for ZONES 0 and 20.

2G1 Version , Gas

4" and 6" (DS 100-150 mm) sizes are available, as **standard** version, or **fillable** version for pressure ranges ≤ 6 bar.

They keep the same functional and constructive features as MGS37 model. They differ from them as follows :

Ambient temperature: -4...+140 °F (-20...+60 °C).

Max process fluid temperature: see table (measured on the lowest point of socket).

Windows: high resistance safety glass.

Dial marking: CE Ex II 2G c T6X TF1, model name and serial/lot number.

Special dial: ranges different from standard, custom artworks and dials without Nuova Fima logo are not available.

Options: plexiglas or tempered glass windows are not available.

Included documentation: Installation manual.

2D1 Version , Gas and Dust

4" and 6" (DS 100-150 mm) are available, as **fillable** version for pressure ranges > 6 bar, or **filled** version.

They keep the same functional and constructive features as MGS37 model. They differ from them as follows :

Damping liquids: glycerine 98%, silicon oil.

Ambient temperature:

+59...+140 °F (+15...+60 °C) for glycerine filling;

-4...+140 °F (-20...+60 °C) for silicon oil filling.

Max process fluid temperature: see table (measured on the lowest point of socket).

Windows: high resistance safety glass.

Dial marking: CE Ex II 2GD c T6X TF1 IP65 T85°C, model name and serial/lot number.

Special dial: ranges different from standard, custom artworks and dials without Nuova Fima logo are not available.

Options: plexiglas or tempered glass windows are not available.

Included documentation: Installation manual.

Class	Instrument case
T6 : 185°F (85°C)	158°F (70°C)
T5 : 212°F (100°C)	185°F (85°C)
T4 : 275°F (135°C)	212°F (100°C)
T3 : 392°F (200°C)	
T2 : 572°F (300°C)	
T1 : 842°F (450°C)	

Technical File: TF1 - Rev. 1 - 21/03/08

NUOVA FIMA

NUOVA FIMA S.p.A. - www.nuovafima.com
P.O. BOX 58 - VIA C. BATTISTI 59 - 28045 INVORIO (NO) ITALY
TEL. +39 0322 253200 - FAX +39 0322 253232

ISO 9001 : 2000
Cert. n° 0433/3



safety pressure gauges "solid-front" ATEX, NACE MR 01.75 / ISO 15156 DS 4", 6" (100-150mm)

MGS41

RBO - 09/09

Versions	
2G1	2D1
II	II
2	2
G	
	GD
T6	T6

Group: all the installations, with exclusion of mines
Category: high level of protection
Explosive atmosphere: inflammable gases
Explosive atmosphere: inflammable gases and dusts
Temperature class: 85°C



These instruments are designed for petrochemical industry. They are built to resist to the most severe conditions created by H₂S and by the environment. The MGS pressure gauges are in conformity with: to the essential Health and Safety Requirements laid down in European Directive 94/9/EC for Group II, Category 2G or 2GD equipment in the T1...T6 temperature classes; to construction and safety specifications of EN 837-1/S3 e ASME B40.1. In case of leaks or break of the elastic element, the operator is protected by a solid separating wall placed on the front of the instrument and by the blow out back. They are NOT suitable for ZONES 0 and 20.

2G1 Version , Gas

4" and 6" (DS 100-150 mm) sizes are available, as **standard** version, or **fillable** version for pressure ranges ≤ 6 bar.

They keep the same functional and constructive features as MGS41 models. They differ from them as follows :

Ambient temperature: -4...+140 °F (-20...+60 °C).

Max process fluid temperature: see table (measured on the lowest point of socket).

Windows: high resistance safety glass.

Dial marking: CE Ex II 2G c T6X TF1, model name and serial/lot number.

Special dial: ranges different from standard, custom artworks and dials without Nuova Fima logo are not available.

Options: plexiglas or tempered glass windows are not available.

Included documentation: Installation manual.

Class	Instrument case
T6 : 185°F (85°C)	158°F (70°C)
T5 : 212°F (100°C)	185°F (85°C)
T4 : 275°F (135°C)	212°F (100°C)
T3 : 392°F (200°C)	
T2 : 572°F (300°C)	
T1 : 842°F (450°C)	

Technical File: TF1 - Rev. 1 - 21/03/08

2D1 Version , Gas and Dust

4" and 6" (DS 100-150 mm) are available, as **fillable** version for pressure ranges > 6 bar, or **filled** version, .

They keep the same functional and constructive features as MGS41 models. They differ from them as follows :

Damping liquids: glycerine 98%, silicon oil or fluorinated fluid.

Ambient temperature:

+59...+140 °F (+15...+60 °C) for glycerine filling;

-4...+140 °F (-20...+60 °C) for silicon oil or fluorinated fluid filling.

Max process fluid temperature: see table (measured on the lowest point of socket).

Windows: high resistance safety glass.

Dial marking: CE Ex II 2GD c T6X TF1 IP65 T85°C, model name and serial/lot number.

Special dial: ranges different from standard, custom artworks and dials without Nuova Fima logo are not available.

Options: Compensating device and plexiglas windows are not available.

Included documentation: Installation manual.

bourdon tube "solid-front" pressure gauges NACE MR0175/ISO 15156-3 version DS 4", 6" (100-150mm)

MGS41



PED 97/23/CE
ATEX 94/9/CE

These instruments are built in conformity with the construction and safety specifications of EN 837-1/S3 e ASME B40.1. In case of leaks or break of the elastic element, the operator is protected by a solid separating wall placed on the front of the instrument and by the blow out back. They are usually used in the petrochemical industry; they are built to resist to the most severe conditions created by H₂S and by the environment. The TIG welding between the case and the process socket, strengthens the instrument and assures a better tight in case of dampening fluid. The advantages of filling the case of the instrument with a dampening fluid are: reduced pointer fluctuation, reduced wear of rotating parts of the movement when pulsant vibrations and pulsations occur. Moreover condensation and corrosive atmospheres which could damage the internal parts.

1.41.1 - Standard Model

Design: EN 837-1.

Safety designation: S1 as per EN 837-2.

Ranges: from -30...0 INHG to 0...6000 psi (from -1...0 to 0...400 bar or equivalent units).

Accuracy class: 1 as per EN 837-1.

Ambient temperature: -13...+149 °F (-25...+65 °C).

Process fluid temperature: -40...+212 °F (-40...+100 °C).

Working pressure:

100% of FSV for static pressure;

90% of FSV for pulsating pressure.

Over pressure limit:

30% of FSV, max 6500 psi - 450 bar (max 12 hours).

Special overpressure (upon request):

1000 psi (60 bar) for pressure > 15 psi (1 bar) ... ≤ 150 psi (10 bar);

3500 psi (250 bar) for pressure > 150 psi (10 bar) ... ≤ 1500 psi (100 bar);

6500 psi (450 bar) for pressure > 1500 psi (100 bar) ... ≤ 6000 psi (400 bar).

Protection degree: IP 55 as per EN 60529/IEC 529.

Bourdon tube: AISI 316L st.st.

Diaphragm seal filling fluid: silicone oil.

Wetted parts: Hastelloy C276.

Leak test: Helium Test leak Search (max 1x10⁻⁶ mbar x l x s⁻¹)

Case: stainless steel.

Ring: stainless steel, bayonet lock.

Blow out disk: stainless steel.

Window: safety glass.

Movement: stainless steel with internal limit stops for minimum and maximum pressure.

Dial: aluminium, white with black markings.

Pointer: adjustable, aluminium, black.

1.41.2 - Fillable Model

Protection degree: IP 67 as per EN 60529/IEC 529.

Other features: as Standard Model.

1.41.3 - Filled Model

Pressure gauges damping liquid:

glycerine 98%, silicon oil or fluorinated fluid.

Ambient temperature:

+32...+149 °F (0...+65 °C) with glycerine filling;

-40...+149 °F (-40...+65 °C) with silicon oil filling;

-40...+149 °F (-40...+65 °C) with fluorinated fluid filling.

Process fluid temperature: max +212 °F (+100 °C).

Protection degree: IP 67 as per EN 60529/IEC 529.

Other features: as Standard Model.

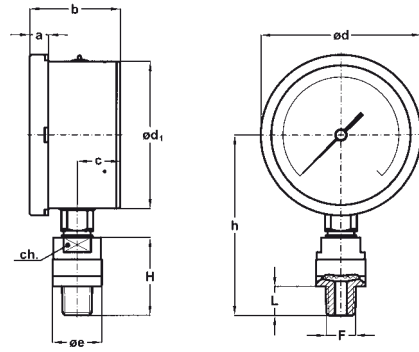

A - LOWER CONNECTION

DS	Ranges	F	a	b	c	ø d	ø d ₁	ø e	h	H	L	ch	Weight (1)
E 4" (100)	≤ 160 psi (10 bar)	43M 1/2-14 NPT	0.51" (13)	2.46" (62,5)	1.16" (29,5)	4.35" (110,6)	3.97" (101)	2.24" (57)	4.86" (123,5)	2.12" (54)	0.78" (20)	1.06" (27)	2.44 lbs (1,11 kg)
	> 160 psi (10 bar)							1.33" (34)					
G 6" (150)	≤ 160 psi (10 bar)	43M 1/2-14 NPT	0.59" (15)	2.52" (64)	1.18" (30)	6.33" (161)	5.88" (149,6)	2.24" (57)	6.12" (155,5)	2.12" (54)	0.78" (20)	1.06" (27)	3.65 lbs (1,66 kg)
	> 160 psi (10 bar)							1.33" (34)					

dimensions : inches (mm)

(1) add 0.72 lbs (0,33 kg) for DS 4" (100) and 1.65 lbs (0,75 kg) for DS 6" (150), when filled

OPTIONS

Model	standard	fillable	filled
2G1 - ATEX II 2G c version	See the ATEX pressure gauges data-sheet for technical details		
2D1 - ATEX II 2GD c version			
C40 - AISI 316L st. st. case and ring	♦	♦	♦
E75 - NACE MR0175/ISO 15156-3 certificate	♦	♦	♦
P02 - Oxygen service	♦	♦ (1)	♦ (2)
P01 - Suitable for filling with silicone and fluorinated fluid		♦	
S10 - Silicone filling			♦
F30 - Fluorinated fluid filling			♦
SPS - Special overpressure	♦	♦	♦
T01 - Tropicalization	♦	♦	♦

(1) to be ordered with instruments suitable for fluorinated fluid filling

(2) to be ordered with fluorinated fluid filled instruments

"HOW TO ORDER" SEQUENCE

Section / Model / Case / Mounting / Diameter / Range / Process connection / Options

1 **41** **1** **A** **E** **43M** **2G1...2D1**
 2 **G** **C40...T01**
 3

bourdon tube pressure gauges

ATEX, NACE MATEX, NACE MR 01.75 / ISO 15156

TEX, NACE MR 01.75 / ISO 15156 01.75 / ISO 15156

DS 4", 6" (100-150mm)

MGS37

RB0 - 09/09



Versions	
2G1	2D1
II	II
2	2
G	
	GD
T6	T6

Group: all the installations, with exclusion of mines

Category: high level of protection

Explosive atmosphere: inflammable gases

Explosive atmosphere: inflammable gases and dusts

Temperature class: 85°C

These instruments are designed for petrochemical industry. They are built to resist to the most severe conditions created by H₂S and by the environment. The MGS pressure gauges are in conformity with the essential Health and Safety Requirements laid down in European Directive 94/9/EC for Group II, Category 2G or 2GD equipment in the T1...T6 temperature classes. They are NOT suitable for ZONES 0 and 20.

2G1 Version , Gas

4" and 6" (DS 100-150 mm) sizes are available, as **standard** version, or **fillable** version for pressure ranges ≤ 6 bar.

They keep the same functional and constructive features as MGS37 model. They differ from them as follows :

Ambient temperature: -4...+140 °F (-20...+60 °C).

Max process fluid temperature: see table (measured on the lowest point of socket).

Windows: high resistance safety glass.

Dial marking: CE Ex II 2G c T6X TF1, model name and serial/lot number.

Special dial: ranges different from standard, custom artworks and dials without Nuova Fima logo are not available.

Options: plexiglas or tempered glass windows are not available.

Included documentation: Installation manual.

2D1 Version , Gas and Dust

4" and 6" (DS 100-150 mm) are available, as **fillable** version for pressure ranges > 6 bar, or **filled** version.

They keep the same functional and constructive features as MGS37 model. They differ from them as follows :

Damping liquids: glycerine 98%, silicon oil.

Ambient temperature:

+59...+140 °F (+15...+60 °C) for glycerine filling;

-4...+140 °F (-20...+60 °C) for silicon oil filling.

Max process fluid temperature: see table (measured on the lowest point of socket).

Windows: high resistance safety glass.

Dial marking: CE Ex II 2GD c T6X TF1 IP65 T85°C, model name and serial/lot number.

Special dial: ranges different from standard, custom artworks and dials without Nuova Fima logo are not available.

Options: plexiglas or tempered glass windows are not available.

Included documentation: Installation manual.

Class	Instrument case
T6 : 185°F (85°C)	158°F (70°C)
T5 : 212°F (100°C)	185°F (85°C)
T4 : 275°F (135°C)	212°F (100°C)
T3 : 392°F (200°C)	
T2 : 572°F (300°C)	
T1 : 842°F (450°C)	

Technical File: TF1 - Rev. 1 - 21/03/08

NUOVA FIMA

NUOVA FIMA S.p.A. - www.nuovafima.com
P.O. BOX 58 - VIA C. BATTISTI 59 - 28045 INVORIO (NO) ITALY
TEL. +39 0322 253200 - FAX +39 0322 253232

ISO 9001 : 2000
Cert. n° 0433/3



safety pressure gauges "solid-front" ATEX, NACE MR 01.75 / ISO 15156 DS 4", 6" (100-150mm)

MGS41

RBO - 09/09

Versions	
2G1	2D1
II	II
2	2
G	
	GD
T6	T6

Group: all the installations, with exclusion of mines
Category: high level of protection
Explosive atmosphere: inflammable gases
Explosive atmosphere: inflammable gases and dusts
Temperature class: 85°C



These instruments are designed for petrochemical industry. They are built to resist to the most severe conditions created by H₂S and by the environment. The MGS pressure gauges are in conformity with: to the essential Health and Safety Requirements laid down in European Directive 94/9/EC for Group II, Category 2G or 2GD equipment in the T1...T6 temperature classes; to construction and safety specifications of EN 837-1/S3 e ASME B40.1. In case of leaks or break of the elastic element, the operator is protected by a solid separating wall placed on the front of the instrument and by the blow out back. They are NOT suitable for ZONES 0 and 20.

2G1 Version , Gas

4" and 6" (DS 100-150 mm) sizes are available, as **standard** version, or **fillable** version for pressure ranges ≤ 6 bar.

They keep the same functional and constructive features as MGS41 models. They differ from them as follows :

Ambient temperature: -4...+140 °F (-20...+60 °C).

Max process fluid temperature: see table (measured on the lowest point of socket).

Windows: high resistance safety glass.

Dial marking: CE Ex II 2G c T6X TF1, model name and serial/lot number.

Special dial: ranges different from standard, custom artworks and dials without Nuova Fima logo are not available.

Options: plexiglas or tempered glass windows are not available.

Included documentation: Installation manual.

Class	Instrument case
T6 : 185°F (85°C)	158°F (70°C)
T5 : 212°F (100°C)	185°F (85°C)
T4 : 275°F (135°C)	212°F (100°C)
T3 : 392°F (200°C)	
T2 : 572°F (300°C)	
T1 : 842°F (450°C)	

Technical File: TF1 - Rev. 1 - 21/03/08

2D1 Version , Gas and Dust

4" and 6" (DS 100-150 mm) are available, as **fillable** version for pressure ranges > 6 bar, or **filled** version, .

They keep the same functional and constructive features as MGS41 models. They differ from them as follows :

Damping liquids: glycerine 98%, silicon oil or fluorinated fluid.

Ambient temperature:

+59...+140 °F (+15...+60 °C) for glycerine filling;

-4...+140 °F (-20...+60 °C) for silicon oil or fluorinated fluid filling.

Max process fluid temperature: see table (measured on the lowest point of socket).

Windows: high resistance safety glass.

Dial marking: CE Ex II 2GD c T6X TF1 IP65 T85°C, model name and serial/lot number.

Special dial: ranges different from standard, custom artworks and dials without Nuova Fima logo are not available.

Options: Compensating device and plexiglas windows are not available.

Included documentation: Installation manual.

bourdon tube "solid-front" pressure gauges NACE MR0175/ISO 15156-3 version turret case - DS 4.5" (125mm)

MGS61



In case of leaks or break of the elastic element the operator is protected by a stainless steel safety cell solid front and by the blow-out back. They are usually used in the petrochemical industry; they are built to resist to the most severe conditions created by H₂S and by the environment and for those fluids. The TIG welding between the safety cell and the process socket strengthens the instrument. The advantages of filling the case of the instrument with a dampening fluid are: reduced pointer fluctuation, reduced wear of rotating parts of the movement when pulsant vibrations and pulsations occur. Moreover condensation and corrosive atmospheres which could damage the internal parts.

1.61.2 - Fillable Model

Design: ASME B40.1

Ranges: from -30...0 INHG to 0...6000 psi (from -1...0 to 0...400 bar or equivalent units).

Accuracy: Grade 1A as per ASME B40.1 ($\pm 1,0\%$ of span).

Ambient temperature: -13...+149 °F (-25...+65 °C).

Process fluid temperature: -40...+212 °F (-40...+100 °C).

Working pressure:

100% of FSV for static pressure;

90% of FSV for pulsating pressure.

Over pressure limit:

30% of FSV, max 6500 psi - 450 bar (max 12 hours).

Special overpressure (upon request):

1000 psi (60 bar) for pressure > 15 psi (1 bar) ... \leq 150 psi (10 bar);

3500 psi (250 bar) for pressure > 150 psi (10 bar) ... \leq 1500 psi (100 bar);

6500 psi (450 bar) for pressure > 1500 psi (10 bar) ... \leq 6000 psi (400 bar).

Protection degree: IP 65 as per EN 60529/IEC 529.

Bourdon tube: AISI 316L st.st.

Diaphragm seal filling fluid: silicone oil.

Wetted parts: Hastelloy C276.

Leak test: Helium Test leak Search (max 1×10^{-6} mbar x l x s⁻¹)

Case and blow out disk: strengthened polyammides with fiber glass, UV rays stabilized.

Ring: strengthened polypropylene, fiber glass.

Safety cell: stainless steel.

Window: tempered glass.

Movement: stainless steel with internal limit stops for minimum and maximum pressure.

Dial: aluminium, white with black markings.

Pointer: adjustable, aluminium, black.

1.61.3 - Filled Model

Pressure gauges damping liquid:

glycerine 98%, silicon oil or fluorinated fluid.

Ambient temperature:

+32...+149 °F (0...+65 °C) with glycerine filling;

-40...+149 °F (-40...+65 °C) with silicon oil filling;

-40...+149 °F (-40...+65 °C) with fluorinated fluid filling.

Process fluid temperature: max +212 °F (+100 °C).

Protection degree: IP 67 as per EN 60529/IEC 529.

Compensating device: gum.

Other features: as Fillable Model.

bourdon tube "solid-front" pressure gauges
NACE MR0175/ISO 15156-3 version,
turret case DS 4.5" (125mm)

MGS61

RM-04/13

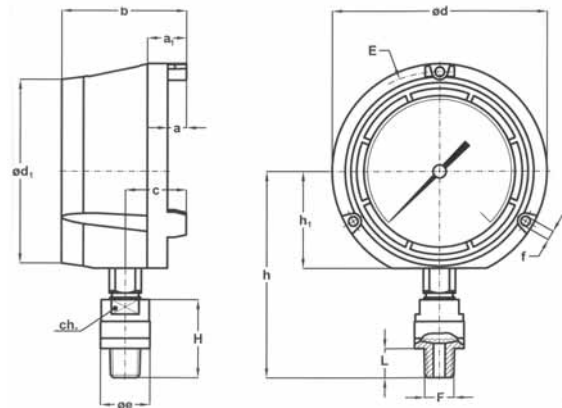

A - LOWER CONNECTION

Ranges	F	a	a ₁	b	c	ø d	ø d ₁	ø e	E	f	h	h ₁	H	L	ch	Weight (1)
≤ 160 psi (10 bar)	43M 1/2-14 NPT	0.51" (13)	1.06" (27)	3.38" (86)	1.65" (42)	5.82" (148)	4.96" (126)	2.24" (57)	5.39" (137)	0.25" (6,5)	5.57" (141,5)	2.61" (66,5)	2.12" (54)	0.78" (20)	1.06" (27)	2.44 lbs (1,11 kg)
> 160 psi (10 bar)								1.33" (34)								

dimensions : inches (mm)

(1) add 1.10 lbs (0,5 kg), when filled

OPTIONS

Model	fillable	filled
E75 - NACE MR0175/ISO 15156-3 certificate	◆	◆
P02 - Oxygen service	◆ (1)	◆ (2)
P01 - Suitable for filling with silicone / fluorinated fluid	◆	
S10 - Silicone filling		◆
F30 - Fluorinated fluid filling		◆
SPS - Special overpressure	◆	◆
T01 - Tropicalization	◆	◆
T32 - Safety glass window	◆	◆

(1) to be ordered with instruments suitable for fluorinated fluid filling

(2) to be ordered with fluorinated fluid filled instruments

"HOW TO ORDER" SEQUENCE

Section / Model / Case / Mounting / Diameter / Range / Process connection / Options
1 61 2 A F 43M E75...T32
3

homogenizer gauges

DS 4" (100mm)

OM

- ✓ - AISI 316L st.st. wetted parts
- ✓ - Ra ≤0,8µm - 32µin (150 Grit) finishing
- ✓ - Damping system
- ✓ - C.I.P. and S.I.P execution
- ✓ - Full traceability



74-05

Autorization NO. 1599



These instruments are designed for homogenizer machines and are built according to standard n. 74-05 of 3-A organization (Sanitary Standards Symbol Administrative Council). The absence of interstices and the mirror finishing of the components assure the best hygiene. The process connection is a special diaphragm seal integrally built with the pressure gauge. To reduce the effects of severe operating conditions like vibrations and pulsations, the instruments can be liquid filled.

1.OM.2 - Fillable model

Design: 74-05 SSI; EN837-1.

Safety designation: S1 as per EN 837-2.

Ranges: from 0...2000 psi to 0...15000 psi; (from 0...160 bar to 0...1600 bar or equivalent units).

Accuracy: class 1,6 as per EN 837-1.

Ambient temperature: -13...+149 °F (-25...+65 °C).

Process temperature: -4...+248 °F (-20...+120 °C).

Max 302°F (150 °C) for 1 hour during cleaning stage (C.I.P.)¹ and sterilization (S.I.P.)².

Working pressure (referred to the full scale value): max 75%.

Over pressure limit: not available.

Seal fill: oil for food service (FDA).

Protection degree: IP 67 as per EN 60529 / IEC 529.

Process connection: AISI 316L st.st. with Ra ≤0,8µm- 32µin (150 Grit) finishing.

Diaphragm: AISI 316L

Welding: AISI 316L TIG.

Flange and screw nut: AISI 316 st.st.

Case: stainless steel.

Ring: stainless steel, bayonet lock.

Elastic element: AISI 316L st.st. spiral form.

Window: tempered glass.

Movement: stainless steel.

Dial: aluminium, white with black markings.

Pointer: aluminium black anodized.

1.OM.3 - Filled model

Case filling liquid: glycerine 99,5% (USP, E.P. and F.U.) for food service.

Ambient temperature: +59...+149 °F (+15...+65 °C).

Other features: as fillable model.

1) C.I.P. = Cleaned In Place

2) S.I.P. = Steamed In Place

RANGES	bar	bar ext. psi int.
0...160	◆	◆
0...250	◆	◆
0...400	◆	◆
0...600	◆	◆
0...1000	◆	◆
0...1600 (1)	◆	◆

RANGES	psi
0...2000	◆
0...3000	◆
0...4000	◆
0...5000	◆
0...6000	◆
0...10000	◆
0...15000	◆

(1) available only with some type of process connections

homogenizer gauges

DS 4" (100mm)

OM

R83-04/13

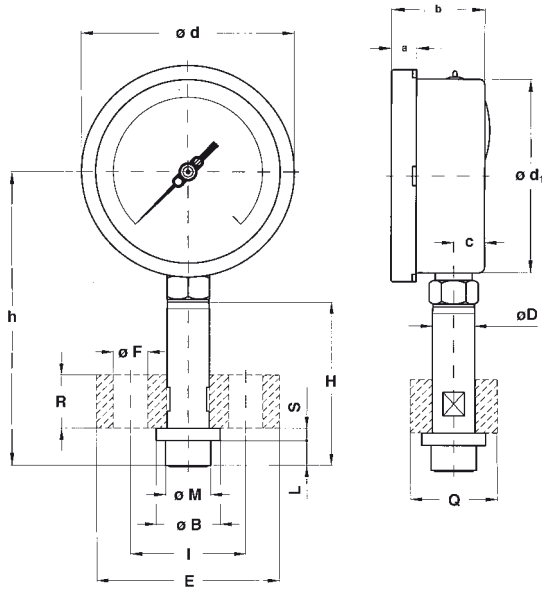

A - LOWER CONNECTION

335 - SA 335
(with flange)

a	b	c	d	d ₁	h
0.51" (13)	1.90" (48,5)	0.62" (16)	4.35" (110,6)	3.97" (101)	6.08" (154,5)

308 - SA 308
(with nut)

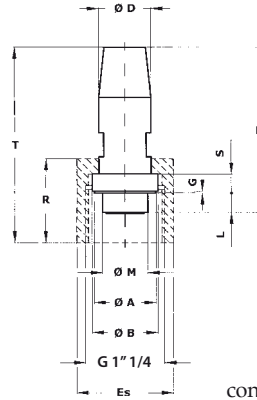

167 - SA 167
422 - SA 422

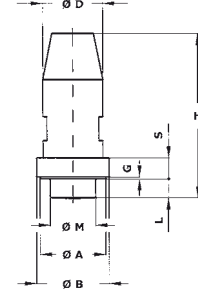

Customer drawing process
connection available on request

Drawing	Ø D	Ø M	Ø A	Ø B	H	S	G	L	Es	E	Ø F	I	R	Q	T	Weight
SA 335	0.86" (22)	0.95" (23,5)		1.30" (33,3)	3.38" (86)	0.25" (6,5)		0.51" (13)		3.74" (95)	0.70" (18)	2.36" (60)	1.10" (28)	1.77" (45)		4.01 lbs (1,82 kg)
SA 308	1.06" (27)	0.95" (23,5)	1.25" (32)	1.33" (34)	3.38" (86)	0.39" (10)	0.04" (1)	0.39" (10)	1.96" (50)				1.73" (44)		4.01" (102)	3.37 lbs (1,53 kg)
SA 167	1.22" (31)	0.95" (23,5)	1.33" (34)	1.47" (37,5)	3.38" (86)	0.43" (11)	0.04" (1)	0.39" (10)								2.84 lbs (1,29 kg)
SA 422	1.22" (31)	1.02" (26)	1.33" (34)	1.47" (37,5)	3.38" (86)	0.43" (11)	0.04" (1)	0.39" (10)								2.86 lbs (1,30 kg)

dimensions : inches (mm)

OPTIONS

Model	Fillable	Filled
S38 - Connection as per SA 308, without nut	♦	♦
S35 - Connection as per SA 335, without flange	♦	♦
2D1 - ATEX II 2GD c version	See the ATEX pressure gauges data-sheet for technical details	
L22 - Maximum pointer IP 65 on plexiglas window (1)	♦	♦
T32 - Safety glass window	♦	♦
TPC - Polycarbonate window	♦	♦

(1) Accuracy refers to the area free from the maximum pointer action.

"HOW TO ORDER" SEQUENCE

Section / Model / Case / Mounting / Diameter / Range / Process connection / Options

1	OM	2	A	E	167	S35...S38
		3			308	2D1...TPC
					335	
					422	

sanitary pressure gauges

DS 2.5", 4" (63-100mm)



74-06

Autorization NO. 1599



These instruments are designed for Sanitary, Food Process and Pharmaceutical Industries in compliance with standard n.74-06 of 3-A (Sanitary Standards Symbol Administrative Council). The absence of interstices and the mirror finishing of the components assure the best hygiene. The combination of pressure gauge and diaphragm seal allow to reduce the inner volumes and temperature error. To reduce the effects of severe working conditions like vibrations and pulsations, the instruments can be filled.

1.SP.2 - Liquid fillable

Design: 74-06 SSI; ASME B40.1

Ranges: from 0...15 psi to 0...600 psi; (from 0...1 bar to 0...40 bar or equivalent units).

Accuracy: grade A as per ASME B40.1 (2-1-2%) for DS 4" (100mm); grade B as per ASME B40.1 (3-2-3%) for DS 2.5" (63mm);

Ambient temperature: -13...+149 °F (-25...+65 °C).

Process temperature: -4...+212 °F (-20...+100 °C).

Max 284°F (140 °C) for 30 minutes during cleaning stage (C.I.P.)¹ and sterilization (S.I.P.)².

Working pressure (referred to the full scale value): max 75%.

Over pressure limit: not available.

Seal fill: mineral oil (FDA approved) for food service.

Protection degree: IP 67 as per EN 60529/IEC 529.

Process connection: AISI 316L st.st. with finishing Ra ≤0,76 µm (welded parts included), as per ASME BPE SF3.

Diaphragm: AISI 316L st.st. .

Welding: AISI 316L TIG.

Case: electro polished AISI 304 st.st.

Ring: polished AISI 304 st.st., crimped.

Window: plastic on DS 2.5" (63mm); tempered glass on DS 4" (100 mm).

Dial: aluminium, white with black markings.

Pointer: aluminium black anodized.

1) C.I.P. = Cleaned In Place

2) S.I.P. = Steamed In Place - available for ranges > 1bar when steam pressure does not exceed the max admissible pressure on the connected instrument

1.SP.3 - Liquid filled

Case fill: glycerine 99,5% (USP, E.P. e F.U.) for food service.

Ambient temperature: +32...+149 °F (0...+65 °C).

Other features: as standard model.

1.SP.2.A.E.ATV - Autoclavable

This version can be autoclaved and sterilized at a max temperature of 304°F (150 °C) for 1 hour.

Window: Polysulfone.

Gasket: silicon rubber.

Blow out vent and filling plug: VITON.

Other features: as standard model.

sanitary pressure gauges

DS 2.5", 4" (63-100mm)

SP

RC4 - 09/15

IN ORDER TO IMPROVE THEIR PRODUCTION, MESSRS. NUOVA FIMA RESERVE THE RIGHT TO THEMSELVES TO MAKE ALL THE MODIFICATIONS THAT THEY DEEM INDISPENSABLE AT ANY TIME. UPDATED DATA SHEETS ARE AVAILABLE ON SITE: www.nuovafima.com

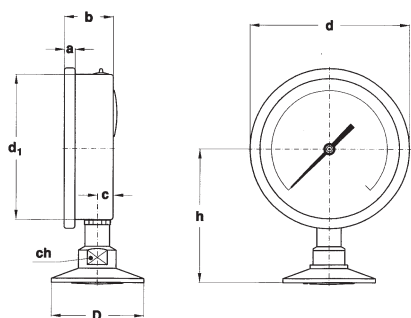

A - LOWER CONNECTION

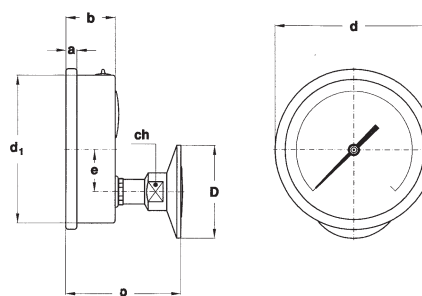

**D - BACK CONNECTION,
FOR DS 4" (100mm) ONLY**

DS	AT- 1 1/2"	D BT- 2"	a	b	c	d	d ₁	e	h	p	ch	Weight (1)
C 2.5" (63 mm)	1.98"	2.51"	0.21"	1.10"	0.39"	2.67"	2.46"		3.11"		0.86"	0.61 lbs
E 4" (100 mm)	1.98"	2.51"	0.29"	1.33"	0.43"	4.33"	0.39"	0.73"	3.50"	2.99"	0.86"	0.92 lbs

(dimensioni : inches)

(1) add 0.26 lbs (0,12 kg) for DS 2.5" (63 mm) and 0.66 lbs (0,30 kg) for DS 4" (100 mm), when filled

RANGES - "C" = DS 2.5" (63mm); "E" = DS 4" (100mm).

PRESSURE

TAB. 1

RANGE	bar
0...1 (1)	E
0...1,6 (1)	E
0...2,5	C-E
0...4	C-E
0...6	C-E
0...10	C-E
0...16	C-E
0...25	C-E
0...40	C-E

TAB. 2

RANGE	psi ext. bar int.
0...15 (1)	E
0...30	C-E
0...60	C-E
0...100	C-E
0...160	C-E
0...200	C-E
0...300	C-E
0...400	C-E
0...600	C-E

VACUUM & COMPOUND

TAB. 3

RANGE	bar
-1...0 (1)	E
-1...0,6 (1)	E
-1...1,5	C-E
-1...3	C-E
-1...5	C-E
-1...9	C-E
-1...15	C-E

TAB. 4

RANGE (2)	psi ext. bar int.
-30...0 (1)	E
-30...15 (1)	E
-30...30	C-E
-30...60	C-E
-30...100	C-E
-30...150	C-E
-30...300	C-E

(1) available only for 2" CLAMP connection

(1) available only for 2" CLAMP connection

(2) vacuum unit of measurement: "inHg"

FINISHING

0 - Ra ≤ 0,51 μm, as per ASME BPE SF1	(1)
A - Ra ≤ 0,51 μm, as per ASME BPE SF1	(1)
B - Ra ≤ 0,38 μm, as per ASME BPE SF4 - electropolished	(1)

(1) welded parts included

OPTIONS

K16 - Accuracy ± 1,6%
TPC - Polycarbonate window

"HOW TO ORDER" SEQUENCE

Section / Model / Case / Mounting / Diameter / Special Version / Range / Process connection / Finishing / Options

1 **SP** **2** **A** **C** **ATV** **AT-** **0** **K16...TPC**
3 **D** **E** **BT-** **A**
B

Copyright © NUOVA FIMA S.p.A. Tutti i diritti riservati. Nessuna parte di questa pubblicazione può essere riprodotta in alcuna forma senza permesso scritto rilasciato da Nuova Fima S.p.A.

NUOVA FIMA USA Inc.
www.nuovafima.com - e-mail: infousa@nuovafima.com
 4123 Hollister, Suite G - TX 77080 Houston
 TEL. +1 713.690.9800 - FAX +1 713.690.9803

NUOVA FIMA srl
www.nuovafima.com - e-mail: info@nuovafima.com
 P.O. BOX 58 - VIA C. BATTISTI 59 - 28045 INVORIO (NO) ITALY
 TEL. +39 0322 253200 - FAX +39 0322 253232



bourdon tube test gauges
all stainless steel construction
class 0,6%
DS 6" (150mm)

MN15

- ✓ - All instruments are supplied with calibration report referred to master primary instrument.

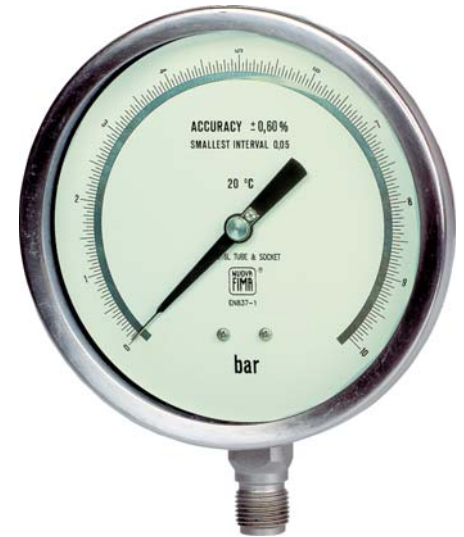

CE Compliance to requirement of PED 97/23/EC

These instruments have been designed for laboratories, instrument testing or recalibration facilities and in other applications where accuracy and repeatability are of primary importance. They can be used with fluids or gasses that do not have high viscosity and do not crystallize. The wetted parts in AISI 316L permits to use them in worse working conditions determined by aggressive ambients or process fluids. Upon request we can supply the calibration certificate issued by an Internationally recognized laboratory of ACCREDIA (Ex S.I.T. - Italian Calibration Service).

1.15.1 - Standard Model

- Design:** EN837-1.
- Safety designation:** S1 as per EN 837-2.
- Accuracy class:** 0,6 as per EN 837-1.
- Ambient temperature:** -13...+149 °F (-25...+65 °C).
- Process fluid temperature:** -40...+302°F (-40...+150 °C).
- Calibration temperature:** 68°F (+20 °C).
- Thermal drift:** ±0,4 % / 10 K of range (starting from 68°F - 20°C).
- Working pressure:** max 75% of FSV.
- Overpressure limit:** 30% of FSV.
- Protection degree:** IP 55 as per IEC 529.
- Socket material:** AISI 316L st.st.
- Bourdon tube:** AISI 316L st.st. seamless tube.
- Case:** stainless steel.
- Ring:** stainless steel, bayonet lock.
- Window:** tempered glass.
- Movement:** stainless steel with internal limit stops fro minimum and maximum pressure.
- Dial:** aluminium,white with black markings and anti-parallax mirror band.
- Pointer:** adjustable, aluminium, black, knife-edge micrometer.

RANGE	Minor graduation	Figure interval	bar	kPa	MPa	psi
-1...0	0,005	0,10	♦			
0...0,6	0,002	0,05	♦		♦	
0...1	0,005	0,1	♦		♦	
0...1,6	0,005	0,1	♦		♦	
0...2,5	0,01	0,1	♦		♦	
0...4	0,02	0,2	♦		♦	
0...6	0,02	0,5	♦		♦	
0...10	0,05	1	♦		♦	♦
0...16	0,05	1	♦		♦	♦
0...25	0,1	1	♦		♦	
0...30	0,1	2	♦		♦	♦
0...40	0,2	2	♦		♦	
0...60	0,2	5	♦	♦	♦	♦
0...100	0,5	10	♦	♦		♦
0...160	0,5	10	♦	♦		♦
0...250	1	10	♦	♦		
0...300	1	20	♦	♦		♦
0...400	2	20	♦	♦		♦
0...600	2	50	♦	♦		♦
0...1000	5	100				♦
0...2000	10	100				♦
0...3000	10	200				♦
0...4000	20	200				♦
0...6000	20	500				♦

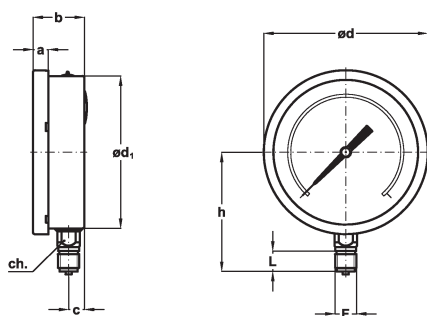

A - LOWER CONNECTION

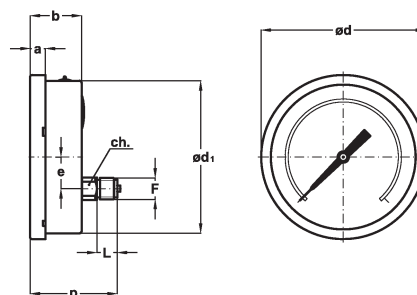

D - BACK CONNECTION

Mounting	F	a	b	c	ød	ød ₁	e	h	p	ch	L	Weight
Lower	41M - G 1/2 A	0.59"	1.91"	1.98"	6.33"	5.88"		4.60"		0.86"	0.78"	2.07 lbs
	43M - 1/2-14 NPT	(15)	(50,5)	(15,5)	(161)	(149,6)		(117)		(22)	(20)	(0,94 kg)
Back	41M - G 1/2 A	0.59"	1.91"		6.33"	5.88"	1.22"		3.36"	0.86"	0.78"	2.07 lbs
	43M - 1/2-14 NPT	(15)	(50,5)		(161)	(149,6)	(31)		(85,5)	(22)	(20)	(0,94 kg)

dimensions : inches (mm)

OPTIONS

B - "U"-clamp, for back connection pressure gauges
C - Back flange, for lower connection pressure gauges
E - Front flange, for back connection pressure gauges
CE1 - ACCREDIA certificate (pressure gauges)
CE3 - ACCREDIA certificate (vacuum gauges)
T32 - Safety glass window

PRESSURE GAUGE HOLDER CASE



Instruments with radial connection can be supplied of pressure gauge holder case, code **5VAL**.

"HOW TO ORDER" SEQUENCE

Section	Model	Case	Mounting	Diameter	Range	Process connection	Options
1	15	1	A	G		41M	B...E
			D			43M	CE1...T32

bourdon tube test gauges
all stainless steel construction, "solid-front"
class 0,6%
DS 6" (150mm)

MN16



✓ - All instruments are supplied with calibration report referred to master primary instrument.

CE Compliance to requirement of PED 97/23/EC

These instruments have been designed for laboratories, instrument testing or recalibration facilities and in other applications where accuracy and repeatability are of primary importance. These instruments have a solid separating wall in stainless steel, placed between the dial and the elastic element and an integral blow out back that is released from the case whenever a pressure is created inside the case, due to leaks or accidental ruptures of the elastic element. They can be used with fluids or gasses that do not have high viscosity and do not crystallize. The wetted parts in AISI 316L permits to use them in worse working conditions determined by aggressive ambients or process fluids. Upon request we can supply the calibration certificate issued by an Internationally recognized laboratory of ACCREDIA (Ex S.I.T. - Italian Calibration Service).

1.16.1 - Standard Model

Design: EN837-1.

Safety designation: S3 as per EN 837-2.

Accuracy class: 0,6 as per EN 837-1.

Ambient temperature: -13...+149 °F (-25...+65 °C).

Process fluid temperature: -40...+302°F (-40...+150 °C).

Calibration temperature: 68°F (+20 °C).

Thermal drift: ±0,4 % / 10 K of range (starting from 68°F - 20°C).

Working pressure: max 75% of FSV.

Overpressure limit: 30% of FSV.

Protection degree: IP 55 as per IEC 529.

Socket material: AISI 316L st.st.

Bourdon tube: AISI 316L st.st. seamless tube.

Case: stainless steel.

Ring: stainless steel, bayonet lock.

Blow out disk: stainless steel

Window: safety glass.

Movement: stainless steel with internal limit stops of minimum and maximum pressure.

Dial: aluminium, white with black markings and anti-parallax mirror band

Pointer: adjustable, aluminium, black, knife-edge micrometer

RANGE	Minor graduation	Figure interval	bar	kPa	MPa	psi
-1...0	0,005	0,10	♦			
0...0,6	0,002	0,05	♦		♦	
0...1	0,005	0,1	♦		♦	
0...1,6	0,005	0,1	♦		♦	
0...2,5	0,01	0,1	♦		♦	
0...4	0,02	0,2	♦		♦	
0...6	0,02	0,5	♦		♦	
0...10	0,05	1	♦		♦	♦
0...16	0,05	1	♦		♦	♦
0...25	0,1	1	♦		♦	
0...30	0,1	2	♦		♦	♦
0...40	0,2	2	♦		♦	
0...60	0,2	5	♦	♦	♦	♦
0...100	0,5	10	♦	♦		♦
0...160	0,5	10	♦	♦		♦
0...250	1	10	♦	♦		
0...300	1	20	♦	♦		♦
0...400	2	20	♦	♦		♦
0...600	2	50	♦	♦		♦
0...1000	5	100				♦
0...2000	10	100				♦
0...3000	10	200				♦
0...4000	20	200				♦
0...6000	20	500				♦

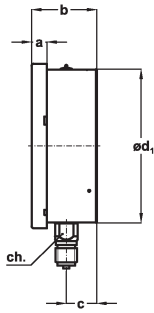

A - LOWER CONNECTION

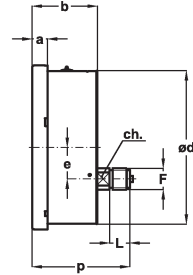
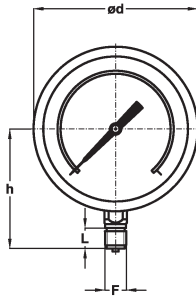

D - BACK CONNECTION

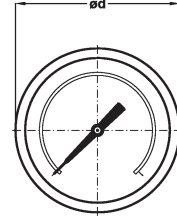

Mounting	F	a	b	c	ch	ød	ød ₁	e	h	p	L	Weight
Lower	41M - G 1/2 A	0.59"	2.51"	1.18"	0.86"	6.33"	5.92"		4.60"		0.78"	2.49 lbs
	43M - 1/2-14 NPT	(15)	(64)	(30)	(22)	(161)	(150,5)		(117)		(20)	(1,13 kg)
Back	41M - G 1/2 A	0.59"	2.51"		0.66"	6.33"	5.92"	1.22"		3.79"	0.78"	2.27 lbs
	43M - 1/2-14 NPT	(15)	(64)		(17)	(161)	(150,5)	(31)		(96,5)	(20)	(1,03 kg)

dimensions : inches (mm)

PRESSURE GAUGE HOLDER CASE



Instruments with radial connection can be supplied of pressure gauge holder case, code **5VAL**.

OPTIONS

C - Back flange, for lower connection pressure gauges
E - Front flange, for back connection pressure gauges
CE1 - ACCREDIA certificate (pressure gauges)
CE3 - ACCREDIA certificate (vacuum gauges)
P02 - Oxygen service

"HOW TO ORDER" SEQUENCE

Section / Model / Case / Mounting / Diameter / Range / Process connection / Options
1 16 1 A G 41M C...E
D 43M CE1...P02

bourdon tube test gauges

"solid-front" , class 0,25%

DS 6" (150mm)

MN17

✓ - All instruments are supplied with calibration report referred to master primary instrument.



CE Compliance to requirement of PED 97/23/EC

These instruments have been designed for laboratories, instrument testing or recalibration facilities and in other applications where accuracy and repeatability are of primary importance. These instruments have a solid separating wall in stainless steel, placed between the dial and the elastic element and an integral blow out back that is released from the case whenever a pressure is created inside the case, due to leaks or accidental ruptures of the elastic element. They can be used with fluids or gasses that do not have high viscosity and do not crystallize. The wetted parts in beryllium copper permits higher accuracy. Upon request we can supply the calibration certificate issued by an Internationally recognized laboratory of ACCREDIA (Ex S.I.T. - Italian Calibration Service).

1.17.1 - Standard Model

Design: EN837-1.

Safety designation: S3 as per EN 837-2.

Accuracy class: 0,25 as per EN 837-1.

Ambient temperature: +59...+149 °F (+15...+65 °C).

Process fluid temperature: +149°F (max +65 °C).

Calibration temperature: 68°F (+20 °C).

Thermal drift: ±0,1 % / 10 K of range (starting from 68°F - 20°C).

Working pressure: max 75% of FSV.

Overpressure limit:

25% of FSV for ranges ≤ 1000 psi (60 bar).

15% of FSV for ranges ≥ 1500 psi (100 bar).

Protection degree: IP 55 as per IEC 529.

Socket material: AISI 316L st.st.

Bourdon tube: beryllium copper alloy.

Case: stainless steel.

Ring: stainless steel, bayonet lock.

Blow out disk: stainless steel.

Window: safety glass.

Movement: high precision type, horology alloy.

Dial: aluminium, green with black markings and anti-parallax mirror band.

Pointer: adjustable, aluminium, black, knife-edge.

RANGE	Minor graduation	Figure interval	bar	kPa	MPa	psi
-1... 0	0,005	0,10	♦			
0... 0,6	0,002	0,05	♦		♦	
0...1	0,005	0,1	♦		♦	
0...1,6	0,005	0,1	♦		♦	
0...2,5	0,01	0,1	♦		♦	
0...4	0,02	0,2	♦		♦	
0...6	0,02	0,5	♦		♦	
0...10	0,05	1	♦		♦	♦
0...16	0,05	1	♦		♦	♦
0...25	0,1	1	♦		♦	
0...30	0,1	2			♦	♦
0...40	0,2	2	♦		♦	
0...60	0,2	5	♦	♦	♦	♦
0...100	0,5	10	♦	♦	♦	♦
0...160	0,5	10	♦	♦		♦
0...250	1	10	♦	♦		
0...300	1	20	♦	♦		♦
0...400	2	20	♦	♦		♦
0...600	2	50	♦	♦		♦
0...1000	5	100	♦			♦
0...2000	10	100				♦
0...3000	10	200				♦
0...4000	20	200				♦
0...6000	20	500				♦
0...10000	50	1000				♦
0...15000	50	1000				♦

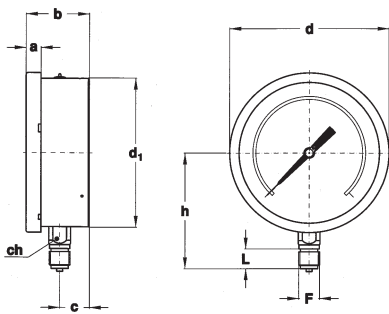

A - LOWER CONNECTION

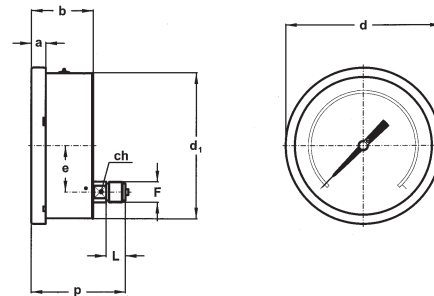

D - BACK CONNECTION

Mounting	F	a	b	c	ch	d	d ₁	e	h	p	L	Weight
Lower	41M - G 1/2 A	0.59"	2.51"	1.14"	0.94"	6.33"	5.92"		4.64"		0.78"	2.62 lbs
	43M - 1/2-14 NPT	(15)	(64)	(29)	(24)	(161)	(150,5)		(118)		(20)	(1,19 kg)
Back	41M - G 1/2 A	0.59"	2.51"		0.66"	6.33"	5.92"	1.88"		3.83"	0.78"	2.42 lbs
	43M - 1/2-14 NPT	(15)	(64)		(17)	(161)	(150,5)	(47,8)		(97,5)	(20)	(1,10 kg)

dimensions : inches (mm)

PRESSURE GAUGE HOLDER CASE



Instruments with radial connection can be supplied of pressure gauge holder case, code **5VAL**.

OPTIONS

C - Back flange, for lower connection pressure gauges
E - Front flange, for back connection pressure gauges
P02 - Oxygen service
CE1 - ACCREDIA certificate (pressure gauges)
CE3 - ACCREDIA certificate (vacuum gauges)

"HOW TO ORDER" SEQUENCE

Section	Model	Case	Mounting	Diameter	Range	Process connection	Options
1	17	1	A	G		41M	C...E
			D			43M	P02...CE3

bourdon tube test gauges
all stainless steel construction, "solid-front"
class 0,25%
DS 6" (150mm)

MN25



- ✓ - All instruments are supplied with calibration report referred to master primary instrument.

These instruments have been designed for laboratories, instrument testing or recalibration facilities and to be used in other applications where accuracy and repeatability are of primary importance. These instruments have a solid separating wall in stainless steel, placed between the dial and the elastic element and an integral blow out back that is released from the case whenever a pressure is created inside the case, due to leaks or accidental ruptures of the elastic element. The process fluids should be gases or liquids, they must not have high viscosity and must not cristalize. The wetted parts in AISI 316L allow to use them in the worst working conditions determined by aggressive medium and environment. Upon request we can supply the calibration certificate issued by an Internationally recognized laboratory of ACCREDIA (Ex S.I.T. - Italian Calibration Service).

1.25.1 - Standard Model

- Design:** EN 837-1.
Safety designation: S3 as per EN 837-2.
Accuracy class: 0,25 as per EN 837-1.
Ambient temperature: -4...+149 °F (-20...+65 °C).
Process fluid temperature: +149°F (max +65 °C).
Calibration temperature: 68°F (+20 °C).
Thermal drift: ±0,4 % / 10 K of range (starting from 68°F - 20°C).
Working pressure: max 75% of FSV
Overpressure limit:
 25% of FSV for ranges up to 1450 psi (100 bar);
 15% of FSV for ranges over 1450 psi (100 bar).
Protection degree: IP 55 as per IEC 529.
Socket material: AISI 316L st.st.
Bourdon tube: AISI 316L st.st. seamless tube.
Case: stainless steel.
Ring: stainless steel, bayonet lock.
Blow out disk: stainless steel.
Window: safety glass.
Movement: high precision, horology alloy.
Dial: aluminium, white with black markings and anti-parallax mirror band.
Pointer: adjustable, aluminium, black, knife-edge micrometer.

RANGE	Minor graduation	Figure interval	bar	kPa	MPa	psi
0...1	0,005	0,1	◆		◆	
0...1,6	0,005	0,1	◆		◆	
0...2,5	0,01	0,1	◆		◆	
0...4	0,02	0,2	◆		◆	
0...6	0,02	0,5	◆		◆	
0...10	0,05	1	◆		◆	
0...16	0,05	1	◆		◆	
0...25	0,1	1	◆		◆	
0...30	0,1	2	◆		◆	◆
0...40	0,2	2	◆		◆	
0...60	0,2	5	◆			◆
0...100	0,5	10	◆	◆		◆
0...160	0,5	10	◆	◆		◆

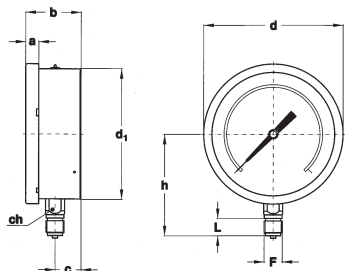

A - LOWER CONNECTION

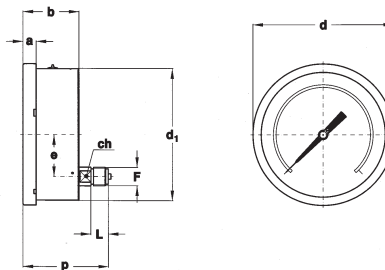

D - BACK CONNECTION

Mounting	F	a	b	c	d	d ₁	e	h	p	L	ch	Weight
Lower	41M G 1/2 A	0.59" (15)	2.51" (64)	1.14" (29)	6.33" (161)	5.92" (150,5)		4.60" (117)		0.78" (20)	0.86" (22)	2.62 lbs (1,19 kg)
Back	43M 1/2-14 NPT	0.59" (15)	2.51" (64)		6.33" (161)	5.92" (150,5)	1.88" (47,8)		3.83" (97,5)	0.78" (20)	0.66" (17)	2.42 lbs (1,10 kg)

dimensions : inches (mm)

PRESSURE GAUGE HOLDER CASE



Instruments with radial connection can be supplied of pressure gauge holder case, code **5VAL**.

OPTIONS

C - Back flange, for lower connection pressure gauges
CE1 - ACCREDIA certificate (pressure gauges)
P02 - Oxygen service

"HOW TO ORDER" SEQUENCE

Section / Model / Case / Mounting / Diameter / Range / Process connection / Options
1 25 1 A G 41M C
D 43M CE1...P02

bourdon tube pressure gauges with microswitch, DS 4" (100mm)

MGS72



CE Compliance to requirements of
LVD 2006/95/EC - PED 97/23/EC

These instruments are designed for applications in conventional power stations. They safety control the automatic regulation of hydraulic and pneumatic equipment.

1.72.1 - Standard Model

Design: EN837-1.

Safety designation: S1 as per EN 837-2.

Ranges: from 0...30 to 0...10000 psi (from 0...1,6 to 0...600 bar or equivalent units).

Accuracy: class 2,5 as per EN 837-1.

Ambient temperature: -13...+149 °F (-25...+65 °C).

Process fluid temperature:

13...+149°F (-25...+65 °C) for ranges ≤ 580 psi (40 bar);

-13...+ 248°F (-25...+120 °C) for ranges ≥ 870 psi (60 bar).

Working pressure: max 75% of the FSV.

Overpressure: not suitable.

Protection degree: IP 44 as per EN 60529/IEC 529.

Electrical specifications: N. 1 SPDT microswitch.

Contact setting: between 10% and 75% of FSV.

Differential: fixed, between 2% and 4% of FSV.

Socket material: copper alloy.

Bourdon tube: copper alloy for ranges ≤ 580 psi (40 bar);

AISI 316L st.st. for ranges > 870 psi (60 bar).

Case: stainless steel.

Ring: stainless steel, bayonet lock.

Window: plastic.

Movement: stainless steel.

Dial: aluminium, white with black markings.

Pressure pointer: aluminium, black.

Set pointer: aluminium, red.

Adjusting key: plastic, removable.

Junction box: glass fibre reinforced poliammid with cable exit ø 0.23...0.35" (6...9 mm) as per EN 175301-803 (Ex DIN 43650).

MICROSWITCH: SETTING

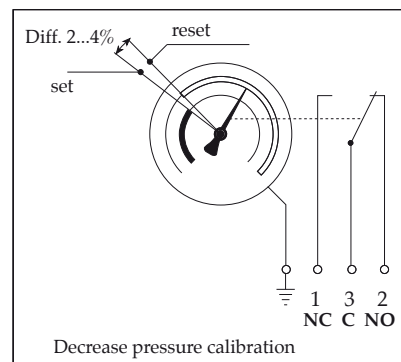
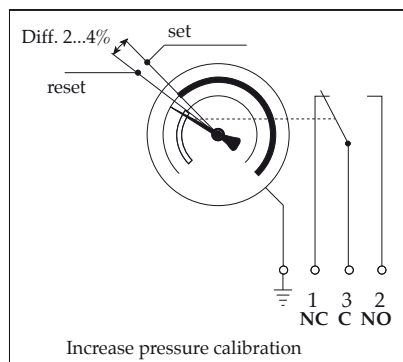

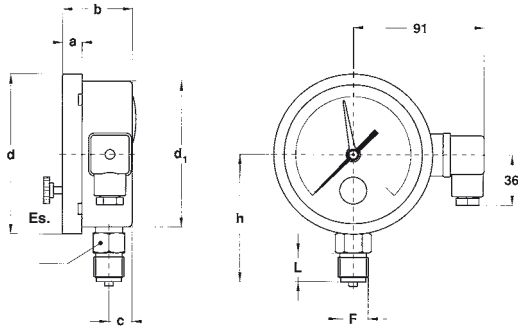

A - LOWER CONNECTION

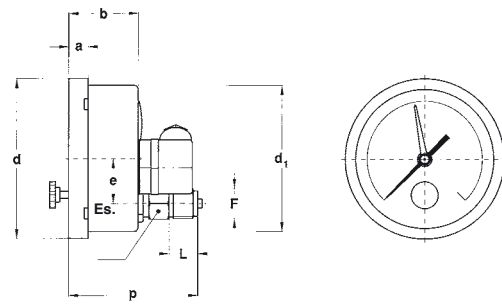

D - BACK CONNECTION

Mounting	F	a	b	c	d	d ₁	e	h	p	L	Es.	Weight
Lower	41M - G 1/2 A	0.51" (13)	1.90" (48,5)	0.62" (16)	4.35" (110,6)	3.97" (101)	1.22" (31)	3.48" (88,5)	3.65" (90)	0.78" (20)	0.86" (22)	1.32 lbs (0,6 kg)
Back												

dimensions : inches (mm)

RATING LOAD

Volt	DC	AC	Inductive load
220	0,3 A	4 A	4 A
110	0,4 A	4 A	4 A
48	4 A	4 A	4 A
24	4 A	4 A	4 A

WIRING

Wiring	Junction box	Cable
NC	Contact N.°1	Brown
NO	Contact N.°2	Black
C	Contact N.°3	Blue
Ground	Ground	Yellow-Green

OPTIONS

RSV - Under-glass adjusting (IP 55 protection degree)
D30 - Differential between 6% and 10% of FSV (for ranges ≥ 60 psi - 2,5 bar)
S06 - Brass restrictor $\varnothing 0.015''$ (0,4 mm) for ranges ≤ 600 psi (40 bar)
T40 - Calibration for pressure decrease

"HOW TO ORDER" SEQUENCE

Section / Model / Case / Mounting / Diameter / Range / Process connection / Options
1 72 1 A E 41M RSV...T40
D

laboratory pressure gauges

class 0,1%

DS 10" (250mm)

MN17/L

- ✓ - All instruments are supplied with calibration report referred to master primary instrument.



These instruments have been designed for use as in laboratories, instrument testing or recalibration facilities or in applications where accuracy and repeatability are of prime importance. They can be used with gaseous or liquid media which do not corrode copper alloy and which do not have high viscosity nor cristalize. Each instruments is delivered with a Nuova Fima calibration report, who guarantee traceability to the national and international primary master of pressure measurements. Upon request we can supply the calibration certificate issued by an Internationally recognized laboratory of ACCREDIA (Ex S.I.T. - Italian Calibration Service).

1.27.1 - Standard Model

Design: EN837-1.

Safety designation: S1 as per EN 837-2.

Accuracy class:

0,1 as per EN837-1, for ranges ≤ 8700 psi (600 bar);

0,25 as per EN837-1, for ranges > 8700 psi (600 bar).

Ambient temperature: $+50...+140^{\circ}\text{F}$ ($+10...+60^{\circ}\text{C}$).

Process fluid temepature: 68°F ($+20^{\circ}\text{C}$).

Calibration temperature: 68°F ($+20^{\circ}\text{C}$).

Thermal drift: $\pm 0,04\%$ / 10 K of range (starting from 68°F - 20°C).

Working pressure: max 75% of FSV

Overpressure limit: not suitable.

Protection degree: IP 44 as per EN 60529 / IEC 529.

Socket material: AISI 316L st.st.

Bourdon tube: beryllium copper alloy.

Case: aluminium black painted.

Ring: aluminium black painted.

Window: plastic.

Movement: high precision.

Dial: aluminium, green with black markings and anti-parallax mirror band.

Scale amplitude: 310° .

Zero calibration: external, manual.

Pointer: balanced, knife-edge micrometer.

PRESSURE GAUGES

RANGES	Minor graduation	Figure interval	bar	kPa	MPa	PSI	bar ext.* kg/cm ² psi int.
0...1	0,002	0,05	♦		♦		
0...1,6	0,005	0,1	♦		♦		
0...2,5	0,005	0,1	♦		♦		♦
0...4	0,01	0,2	♦		♦		♦
0...6	0,02	0,5	♦		♦		♦
0...10	0,02	1	♦		♦		♦
0...16	0,05	1	♦		♦	♦	♦
0...25	0,05	0,5	♦		♦	♦	♦
0...40	0,1	2	♦		♦	♦	♦
0...60	0,2	5	♦		♦	♦	♦
0...100	0,2	5	♦	♦	♦	♦	♦
0...160	0,5	10	♦	♦	♦	♦	♦
0...250	0,5	10	♦	♦		♦	♦
0...400	1	20	♦	♦		♦	♦
0...600	2	50	♦	♦		♦	♦
0...1000	2	50	♦	♦		♦	♦
0...1600	5	100	♦	♦		♦	♦

* accuracy refers to the outer scale.

VACUUM

RANGES	Figure interval	Minor graduation	bar ext.* mm Hg inch Hg int.
-1±0	0,002	0,02	♦

* accuracy refers to the outer scale.

pressure gauges with electric contacts DS 4" (100mm)

MCE10



CE Compliance to requirements of
LVD 2006/95/EC - PED 97/23/EC

They are used to control the electrical operation of compressors, pumps, presses, hydraulic and pneumatics equipment. The contacts open or close the circuit depending on the position of the indicating pointer and they are adjustable over the whole range. For application on severe working conditions, such as rapid and frequent pressure change, vibration and pulsation, they are manufactured with the case liquid filled. The filling drastically reduces the effect of such factors as well as those caused by a corrosive atmosphere, giving longer life and better performances of the pressure gauge and their electric contacts. They are also available with inductive contacts intrinsically safe.

1.M1.1 - Standard Model

Ranges: from 0...30 to 0...15000 *psi* (from 0...1 to 0...1000 bar or equivalent units).

Mechanical contact: sliding contact, magnetic snap-action, electronic, inductive.

Accuracy: $\pm 1,0\%$ as per EN 837-1 - DIN 16085 (1).

Ambient temperature: $-13...+149$ °F ($-25...+65$ °C).

Process fluid temperature: *max* $+212$ °F ($+100$ °C).

Working pressure: max 75% of the full scale value.

Over pressure: not suitable.

Protection: IP 55 as per EN 60529/IEC 529.

Socket material: copper alloy .

Elastic element:

copper alloy for pressure ranges ≤ 580 *psi* (40 bar);

AISI 316 L st.st. for pressure ranges ≥ 870 *psi* (60 bar).

Case: stainless steel.

Ring: stainless steel, bayonet lock.

Window: plastic.

Movement: stainless steel.

Dial: aluminium, white with black markings.

Pointer: not adjustable, aluminium, black.

1.M1.3 - Filled Model

Mechanical contact: magnetic snap-action, electronic, inductive.

Accuracy: $\pm 1,6\%$ as per EN 837-1 - DIN 16085 (1).

Filling liquid: silicon oil.

Protection: IP 65 as per EN 60529/IEC 529.

Other features: as Standard Model.

(1) The addition of mechanical electric contacts affects the accuracy of instruments such that 1% becomes 1,5%, 1,6% becomes 2,4% etc. (add the 50% of accuracy; if the contact is of the magnetically assisted type, this value can't be added within the $\pm 5\%$ of setting point).

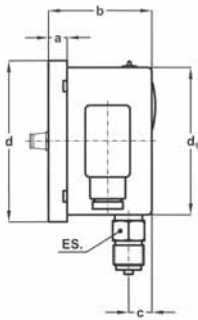

A - LOWER CONNECTION

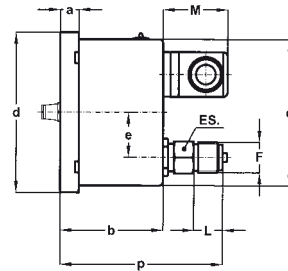
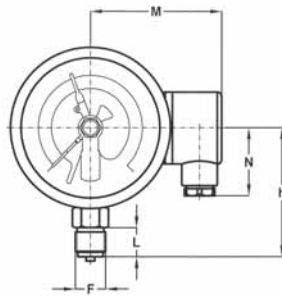

D - BACK CONNECTION

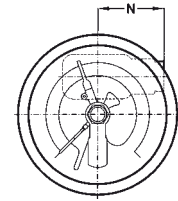

Mounting	F	a	b (1)	c	d	d ₁	e	h	p (1)	N	L	ch	Weight (2)
Lower	41M G 1/2 A	0.51" (13)	2.81" - 3.24" (71,5 - 82,5)	0.63" (16.1)	4.35" (110,6)	3.97" (101)		3.48" (88,5)		1.81" (46)	0.78" (20)	0.86" (22)	1.54 lbs (0,7 kg)
Back	43M 1/2-14 NPT						1.22" (31)		4.44" - 4.87" (112,9 - 123,9)				

dimensions : inches (mm)

(1) dimensions for single / double contact;
(2) when filled, add 0.77 lbs (0,35 kg) for single contact and 0.88 lbs (0,4 kg) for double contact

CONTACT TYPE (1)

MODEL	Standard			Filled		
	Sliding contact, electronic			Magnetic snap-action contact, electronic		
Contact type						
Contact number	1	2	2 independent	1	2	2 independent
Junction box	3 poles + GND	3 poles + GND	6 poles + GND	6 poles + GND	6 poles + GND	6 poles + GND
ø exit cables: inches (mm)	0,23...0,35 (6...9)	0,23...0,35 (6...9)	0,27...0,51 (7...13)	0,27...0,51 (7...13)	0,27...0,51 (7...13)	0,27...0,51 (7...13)
Minimum range	15 psi (1bar)	23 psi (1,6 bar)	23 psi (1,6 bar)	23 psi (1,6 bar)	36 psi (2,5 bar)	36 psi (2,5 bar)

(1) Functional characteristics, electric diagrams and contact types are available on data-sheets
: "ELECTRIC CONTACTS", "ELECTRONIC CONTACTS"

OPTIONS

C - Back flange, for lower connection pressure gauges
E - Front flange, for back connection pressure gauges
E65 - Protection IP 65, for standard model

"HOW TO ORDER" SEQUENCE

Section / Model / Case / Mounting / Diameter / Range / Process connection / Electric contact / Options
1 **M1** **1** **A** **E** **41M** **01S...M9D** **C, E**
3 **D** **43M** **E65**

pressure gauges with electric contacts DS 4", 6" (100-150 mm)

MN14/10



CE Compliance to requirements of
LVD 2006/95/EC - PED 97/23/EC

Alarm contacts are accessories with movable contacts in air, which open or close electric circuits depending of the position of the indicating pointer. They are used with Bourdon tube pressure gauges, bellows, diaphragm and thermometers of NUOVA FIMA production, in such way they become pressure and temperature switches: the optimal and sure solution to automatize any kind of equipment.

1.M7.1 - Standard Model

Ranges: from 0...30 to 0...15000 psi (from 0...1.6 to 0...1000 bar or equivalent units).

Mechanical contact: sliding contact, magnetic snap-action, electronic, inductive.

Accuracy: $\pm 1,0\%$ as per EN 837-1 - DIN 16085 (1).

Ambient temperature: -13...+149 °F (-25...+65 °C).

Process fluid temperature: max +149°F (+65 °C).

Working pressure: max 75% of the full scale value.

Over pressure: not suitable.

Protection: IP 44 as per EN 60529/IEC 529.

Socket material: copper alloy .

Elastic element:

copper alloy for pressure ranges ≤ 580 psi (40 bar);

AISI 316 L st.st. for pressure ranges ≥ 870 psi (60 bar).

Case: stainless steel.

Ring: stainless steel, bayonet lock.

Window: plastic.

Movement: stainless steel.

Dial: aluminium, white with black markings.

Pointer: not adjustable, aluminium, black

(1) The addition of mechanical electric contacts affects the accuracy of instruments such that 1% becomes 1,5%, 1,6% becomes 2,4% etc. (add the 50% of accuracy; if the contact is of the magnetically assisted type, this value can't be added within the $\pm 5\%$ of setting point).

pressure gauges with electric contacts
DS 4", 6" (100-150 mm)

MN14/10

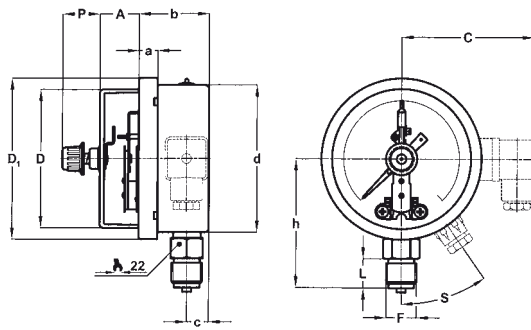

A - LOWER CONNECTION

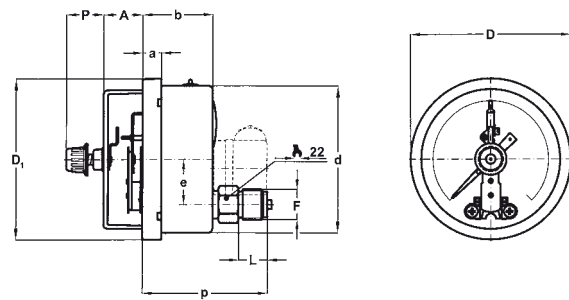

D - BACK CONNECTION

DS	Mounting	F	A (1)	a	b	C	c	D	D ₁	d	e	h	L	P	p	S
E 4" (100)	Lower	41M G 1/2 A	1.06"...2.36" (27...60)	0.51" (13)	1.91" (48,5)	2.72" (69)	0.59" (15)	3.74" (95)	4.35" (110,6)	3.98" (101)		3.39" (86)	0.79" (20)	0.77" (19,6)		35°
	Back	43M 1/2-14 NPT									1.22" (31)				3.54" (90)	
G 6" (150)	Lower	41M G 1/2 A	1.02"...2.32" (26...59)	0.59" (15)	1.99" (50,5)	2.72" (69)	0.61" (15,5)	5.55" (141)	6.34" (161)	5.89" (149,6)		4.61" (117)	0.79" (20)	0.77" (19,6)		35°
	Back	43M 1/2-14 NPT									1.88" (47,8)				3.50" (89)	

dimensions : inches (mm)

(1) dimensions for single / double contact;

CONTACT TYPE (1)

MODEL	DS 4" (100 mm)			DS 6" (150 mm)		
Contact type	Sliding and magnetic snap-action contact			Sliding and magnetic snap-action contact		
Contact number	1	2	2 independent	1	2	2 independent
Junction box ø exit cables: inches (mm)	3 poles + GND 0,23...0,35 (6...9)	3 poles + GND 0,23...0,35 (6...9)		3 poles + GND 0,23...0,35 (6...9)	3 poles + GND 0,23...0,35 (6...9)	
Cable exit ø cable: inches (mm)	2 poles + GND (2) 0,19 (4,8)	3 poles + GND (2) 0,23 (6)	4 poles + 1 0,27 (7)	2 poles + GND (2) 0,19 (4,8)	3 poles + GND (2) 0,23 (6)	4 poles + 1 0,27 (7)
Minimum range	15 psi (1bar)	23 psi (1,6 bar)	23 psi (1,6 bar)	15 psi (1bar)	23 psi (1,6 bar)	23 psi (1,6 bar)

(1) Functional characteristics, electric diagrams and contact types are available on data-sheets : "ELECTRIC CONTACTS".

(2) U-clamp back connection pressure gauges only.

OPTIONS

Model
B - "U"-clamp, for back connection pressure gauges
C - Back flange, for lower connection pressure gauges
E - Front flange, for back connection pressure gauges
CH1 - Removable key, protection IP 55

"HOW TO ORDER" SEQUENCE

Section / Model / Case / Mounting / Diameter / Range / Process connection / Electric contact / Options
1 M7 1 A E 41M 01S...M9D B, C, E
CH1 D G 43M

**bourdon tube pressure gauges
all stainless steel construction,
with microswitch,
DS 4" (100mm)**

MGS74



CE Compliance to requirements of
LVD 2006/95/EC - PED 97/23/EC

These instruments are designed for applications in the chemical, petrochemical industries, conventional power stations. They safety control the automatic regulation of hydraulic and pneumatic equipment.

1.74.1 - Standard Model

Design: EN837-1.

Safety designation: S1 as per EN 837-2.

Ranges: from 0...15 to 0...10000 psi (from 0...1 to 0...600 bar or equivalent units).

Accuracy: class 2,5 as per EN 837-1.

Ambient temperature: -13...+149 °F (-25...+65 °C).

Process fluid temperature: -40...+302 °F (-40...+150 °C).

Working pressure: max 75% of the FSV.

Overpressure: not suitable.

Protection degree: IP 44 as per EN 60529 / IEC 529.

Electrical specifications: N. 1 SPDT microswitch.

Contact setting: between 10% and 75% of FSV.

Differential: fixed, between 2% and 4% of FSV.

Socket material: AISI 316L st.st.

Elastic element: AISI 316L st.st.

Case: stainless steel.

Ring: stainless steel, bayonet lock.

Window: plastic.

Movement: stainless steel.

Dial: aluminium, white with black markings.

Pressure pointer: aluminium, black.

Set pointer: aluminium, red.

Adjusting key: plastic, removable.

Junction box: glass fibre reinforced poliammid with cable exit \varnothing 0.23...0.35" (6...9 mm) as per EN 175301-803 (Ex DIN 43650).

MICROSWITCH: SETTING

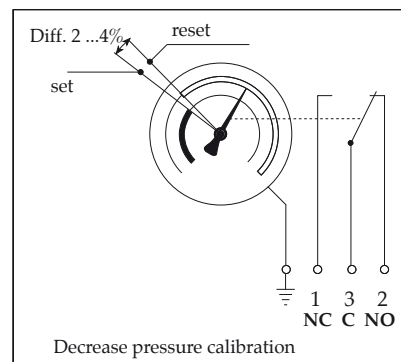
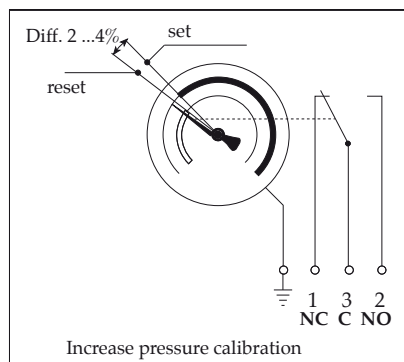

**bourdon tube pressure gauges, all stainless steel construction
with microswitch, DS 4" (100mm)**

MG574

RR-04/13

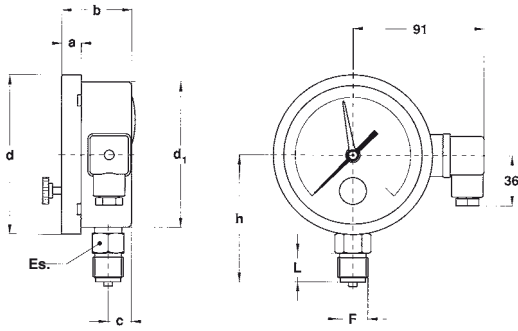

A - LOWER CONNECTION

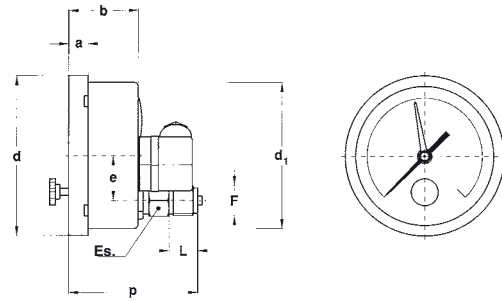

D - BACK CONNECTION

Mounting	F	a	b	c	d	d ₁	e	h	p	L	Es.	Weight
Lower	41M - G 1/2 A	0.51" (13)	1.90" (48,5)	0.62" (16)	4.35" (110,6)	3.97" (101)	1.22" (31)	3.48" (88,5)	3.65" (90)	0.78" (20)	0.86" (22)	1.32 lbs (0,6 kg)
Back												

dimensions : inches (mm)

RATING LOAD

Volt	DC	AC	Inductive load
220	0,3 A	4 A	4 A
110	0,4 A	4 A	4 A
48	4 A	4 A	4 A
24	4 A	4 A	4 A

WIRING

Wiring	Junction box	Cable
NC	Contact N.º1	Brown
NO	Contact N.º2	Black
C	Contact N.º3	Blue
Ground	Ground	Yellow-Green

OPTIONS

RSV - Under-glass adjusting (IP 55 protection degree)
D30 - Differential between 6% and 10% of FSV (for ranges ≥ 60 psi - 2,5 bar)
S06 - Brass restrictor ø 0.015" (0,4 mm) for ranges ≤ 600 psi (40 bar)
T40 - Calibration for pressure decrease

"HOW TO ORDER" SEQUENCE

Section / Model / Case / Mounting / Diameter / Range / Process connection / Options
1 74 1 A E 41M RSV...T40
D

pressure gauges with electric contacts all stainless steel construction DS 4" (100mm)

MCE18



CE Compliance to requirements of
LVD 2006/95/EC - PED 97/23/EC

They are used to control the electrical operation of compressors, pumps, presses, hydraulic and pneumatics equipment, chemical and petrochemical plant. The contacts open or close the circuit depending on the position of the indicating pointer and they are adjustable over the whole range. For application on severe working conditions, such as rapid and frequent pressure change, vibration and pulsation, they are manufactured with the case liquid filled. The filling drastically reduces the effect of such factors as well as those caused by a corrosive atmosphere, giving longer life and better performances of the pressure gauge and their electric contacts. They are also available with inductive contacts intrinsically safe.

1.M2.1 - Standard Model

Ranges: from 0...15 to 0...20000 psi (from 0...1 to 0...1600 bar or equivalent units).

Mechanical contact: sliding contact, magnetic snap-action, electronic, inductive.

Accuracy: $\pm 1,0\%$ as per EN 837-1 - DIN 16085 (1).

Ambient temperature: $-13...+149\text{ }^{\circ}\text{F}$ ($-25...+65\text{ }^{\circ}\text{C}$).

Process fluid temperature: *max* $+212\text{ }^{\circ}\text{F}$ ($+100\text{ }^{\circ}\text{C}$).

Working pressure: *max* 75% of the full scale value.

Over pressure: not suitable.

Protection: IP 55 as per EN 60529/IEC 529.

Socket material: AISI 316L st.st.

Elastic element: AISI 316L st.st.

Case: stainless steel.

Ring: stainless steel, bayonet lock.

Window: plastic.

Movement: stainless steel.

Dial: aluminium, white with black markings.

Pointer: not adjustable, aluminium, black.

1.M2.3 - Filled Model

Mechanical contact: magnetic snap-action, electronic, inductive.

Accuracy: $\pm 1,6\%$ as per EN 837-1 - DIN 16085 (1).

Process fluid temperature: *max* $+149\text{ }^{\circ}\text{F}$ ($+65\text{ }^{\circ}\text{C}$).

Filling liquid: silicon oil.

Protection: IP 65 as per EN 60529/IEC 529.

Other features: as Standard Model.

(1) The addition of mechanical electric contacts affects the accuracy of instruments such that 1% becomes 1,5%, 1,6% becomes 2,4% etc. (add the 50% of accuracy; if the contact is of the magnetically assisted type, this value can't be added within the $\pm 5\%$ of setting point).

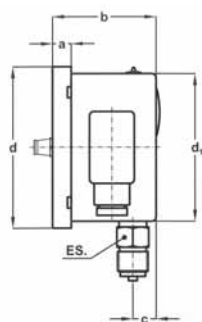

A - LOWER CONNECTION

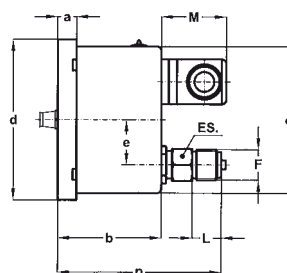
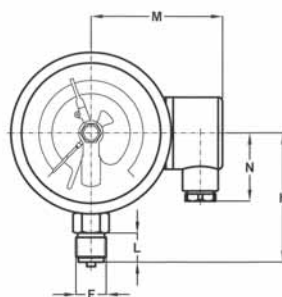

D - BACK CONNECTION

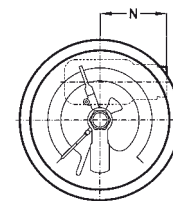

Mounting	F	a	b (1)	c	d	d ₁	e	h	p (1)	N	L	ch	Weight (2)
Lower	41M G 1/2 A	0.51"	2.81" - 3.24"	0.63" (16,1)	4.35" (110,6)	3.97" (101)		3.48" (88,5)		1.81" (46)	0.78" (20)	0.86" (22)	1.54 lbs (0,7 kg)
Back	43M 1/2-14 NPT	(13)	(71,5 - 82,5)				1.22" (31)		4.44" - 4.87" (112,9 - 123,9)				

dimensions : inches (mm)

(1) dimensions for single / double contact;
 (2) when filled, add 0.77 lbs (0,35 kg) for single contact and 0.88 lbs (0,4 kg) for double contact

CONTACT TYPE (1)

MODEL	Standard			Filled		
	Sliding contact, electronic			Magnetic snap-action contact, electronic		
Contact type						
Contact number	1	2	2 independent	1	2	2 independent
Junction box	3 poles + GND	3 poles + GND	6 poles + GND	6 poles + GND	6 poles + GND	6 poles + GND
ø exit cables: inches (mm)	0,23...0,35 (6...9)	0,23...0,35 (6...9)	0,27...0,51 (7...13)	0,27...0,51 (7...13)	0,27...0,51 (7...13)	0,27...0,51 (7...13)
Minimum range	15 psi (1bar)	23 psi (1,6 bar)	23 psi (1,6 bar)	23 psi (1,6 bar)	36 psi (2,5 bar)	36 psi (2,5 bar)

(1) Functional characteristics, electric diagrams and contact types are available on data-sheets :
 "ELECTRIC CONTACTS", "ELECTRONIC CONTACTS"

OPTIONS

ATEX version, with intrinsic safety inductive contact (1)
C - Back flange, for lower connection pressure gauges
E - Front flange, for back connection pressure gauges
E65 - Protection IP 65 as per IEC 529, for standard model

(1) See ATEX data-sheet for technical details

"HOW TO ORDER" SEQUENCE

Section / Model / Case / Mounting / Diameter / Range / Process connection / Electric contact / Options
1 M2 1 A E 41M 01S...M9D C, E
3 D 43M E1...B22 E65

pressure gauges with electric contacts
all stainless steel execution
DS 4", 6" (100-150 mm)

MN14/18

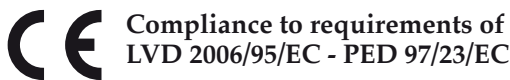

Compliance to requirements of
LVD 2006/95/EC - PED 97/23/EC

Alarm contacts are accessories with movable contacts in air, which open or close electric circuits depending of the position of the indicating pointer. They are used with Bourdon tube pressure gauges, bellows, diaphragm and thermometers of NUOVA FIMA production, in such way they become pressure and temperature switches: the optimal and sure solution to automatize any kind of equipment.

1.M8.1 - Standard Model

Ranges: from 0...15 to 0...20000 *psi* (from 0...1 to 0...1600 bar or equivalent units).

Mechanical contact: sliding contact, magnetic snap-action, electronic, inductive.

Accuracy: $\pm 1,0\%$ as per EN 837-1 - DIN 16085 (1).

Ambient temperature: -13...+149 °F (-25...+65 °C).

Process fluid temperature: *max* +212°F (+100 °C).

Working pressure: max 75% of the full scale value.

Over pressure: not suitable.

Protection: IP 44 as per EN 60529/IEC 529.

Socket material: AISI316L st.st.

Elastic element: AISI316L st.st.

Case: stainless steel.

Ring: stainless steel, bayonet lock.

Window: plastic.

Movement: stainless steel.

Dial: aluminium, white with black markings.

Pointer: not adjustable, aluminium, black

(1) The addition of mechanical electric contacts affects the accuracy of instruments such that 1% becomes 1,5%, 1,6% becomes 2,4% etc. (add the 50% of accuracy; if the contact is of the magnetically assisted type, this value can't be added within the $\pm 5\%$ of setting point).

pressure gauges with electric contacts, all stainless steel execution,
DS 4", 6" (100-150 mm)

MN14/18

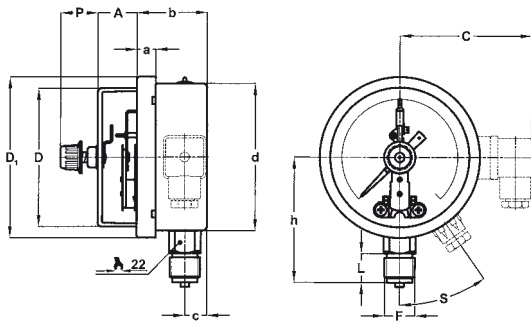

A - LOWER CONNECTION

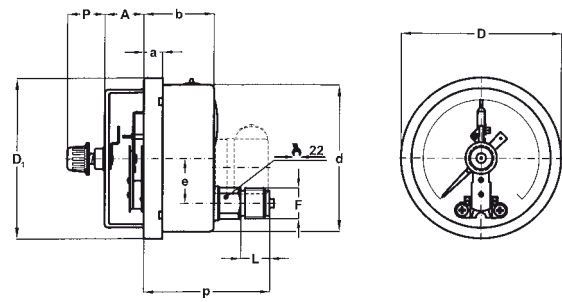

D - BACK CONNECTION

DS	Mounting	F	A (1)	a	b	C	c	D	D ₁	d	e	h	L	P	p	S
E 4" (100)	Lower	41M G 1/2 A	1.06"...2.36" (27...60)	0.51" (13)	1.91" (48,5)	2.72" (69)	0.59" (15)	3.74" (95)	4.35" (110,6)	3.98" (101)		3.39" (86)	0.79" (20)	0.77" (19,6)		35°
	Back	43M 1/2-14 NPT									1.22" (31)				3.54" (90)	
G 6" (150)	Lower	41M G 1/2 A	1.02"...2.32" (26...59)	0.59" (15)	1.99" (50,5)	2.72" (69)	0.61" (15,5)	5.55" (141)	6.34" (161)	5.89" (149,6)		4.61" (117)	0.79" (20)	0.77" (19,6)		35°
	Back	43M 1/2-14 NPT									1.22" (31)				3.50" (89)	

dimensions : inches (mm)

(1) dimensions for single/double contact;

CONTACT TYPE (1)

MODEL	DS 4" (100 mm)			DS 6" (150 mm)		
Contact type	Sliding and magnetic snap-action contact					
Contact number	1	2	2 independent	1	2	2 independent
Junction box ø exit cables: inches (mm)	3 poles + GND 0,23...0,35 (6...9)	3 poles + GND 0,23...0,35 (6...9)		3 poles + GND 0,23...0,35 (6...9)	3 poles + GND 0,23...0,35 (6...9)	
Cable exit ø cable: inches (mm)	2 poles + GND (2) 0,19 (4,8)	3 poles + GND (2) 0,23 (6)	4 poles + 1 0,27 (7)	2 poles + GND (2) 0,19 (4,8)	3 poles + GND (2) 0,23 (6)	4 poles + 1 0,27 (7)
Minimum range	15 psi (1bar)	23 psi (1,6 bar)	23 psi (1,6 bar)	15 psi (1bar)	23 psi (1,6 bar)	23 psi (1,6 bar)

(1) Functional characteristics, electric diagrams and contact types are available on data-sheets : "ELECTRIC CONTACTS".

(2) U-clamp back connection pressure gauges only.

OPTIONS

B - "U"-clamp, for back connection pressure gauges
C - Back flange, for lower connection pressure gauges
E - Front flange, for back connection pressure gauges
CH1 - Removable key, protection IP 55

"HOW TO ORDER" SEQUENCE

Section / Model / Case / Mounting / Diameter / Range / Process connection / Electric contact / Options
1 M8 1 A E 41M 01S...M9D B, C, E
D G 43M CH1

pressure gauges with electric contacts all stainless steel construction DS 6" (150mm)

MCE20



CE Compliance to requirements of
LVD 2006/95/EC - PED 97/23/EC

These instruments are manufactured in accordance with the safety norms prescribed by UNI 8541, DIN 16006 e ANSI B40.1. They are used to control the electrical operation of compressors, pumps, presses, hydraulic and pneumatic equipments, chemical and petrochemical plant. In the event of leakage or break of sensing element, the operator is protected by a solid baffle wall placed on the instrument front and by the rear blow out wall. The contacts open or close the circuit depending on the position of the indicating pointer and they are adjustable over the whole range. For application on severe working conditions, such as rapid and frequent pressure change, vibration and pulsation, they are manufactured with the case liquid filled. The filling drastically reduce the effects of such factors as well as those caused by the corrosive atmosphere, making longer life and better performances of the pressure gauge and their electric contacts. They are also available with inductive contacts intrinsically safe.

1.M3.1 - Standard Model

Ranges: from 0...15 to 0...20000 psi (from 0...1 to 0...1600 bar or equivalent units).

Mechanical contact: sliding contact, magnetic snap-action, electronic, inductive.

Accuracy: $\pm 1,0\%$ as per EN 837-1 - DIN 16085 (1).

Ambient temperature: $-13...+149\text{ }^{\circ}\text{F}$ ($-25...+65\text{ }^{\circ}\text{C}$).

Process fluid temperature: *max* $+212\text{ }^{\circ}\text{F}$ ($+100\text{ }^{\circ}\text{C}$).

Working pressure: *max* 75% of the full scale value.

Over pressure: not suitable.

Protection: IP 55 as per EN 60529/IEC 529.

Socket material: AISI 316L st.st.

Elastic element: AISI 316L st.st.

Case: stainless steel.

Ring and blow out disk: stainless steel.

Window: plastic.

Movement: stainless steel.

Dial: aluminium, white with black markings.

Pointer: not adjustable, aluminium, black.

1.M3.3 - Filled Model, Lower connection only

Mechanical contact: magnetic snap-action.

Accuracy: $\pm 1,6\%$ as per EN 837-1 - DIN 16085 (1).

Process fluid temperature: *max* $+149\text{ }^{\circ}\text{F}$ ($+65\text{ }^{\circ}\text{C}$).

Protection: IP 65 as per EN 60529/IEC 529.

Filling liquids: silicone dielectric oil.

Other features: as Standard Model.

(1) The addition of mechanical electric contacts affects the accuracy of instruments such that 1% becomes 1,5%, 1,6% becomes 2,4% etc. (add the 50% of accuracy; if the contact is of the magnetically assisted type, this value can't be added within the $\pm 5\%$ of setting point).

Pressure gauges for SF₆ gas monitoring DS 4" (100 mm)



These instruments are manufactured to monitor the electrical operations on hermetically sealed systems containing Sulphur Hexafluoride gas (SF₆). The indication and the electrical operations are calibrated to the gas density (isochore) according to the relation pressure-temperature. The M5 model is suitable for indoor installation while the M6 model has been designed for the outdoor installation as well. The oil filled executions are particularly suitable for installation when vibrations are apparent.

Accuracy of indication (referred to the instruments range):

±1% at +20 °C of ambient temperature; ±2,5%
within the temperature range -20...+60°C related to the calibration
pressure of the reference isochore.

Accuracy of intervention:

- see accuracy of indication for set-point equal to pressure of calibration;
- when set-point is different from pressure of calibration, calculate it according to the instrument range.

Alarm contacts, non adjustable contacts, with antitampering sealing:

- on air with magnetic block (80%Ag-20%Ni);
- inductive with galvanic exit.

Ambient temperature: -20...+60 °C.

Storage temperature: -50...+80°C

Calibration pressure (PC): refer to order specifications.

Ranges: also vacuum & compound gauges from 1,6 to 25 bar.

Electrical connection: junction box with cable gland M20 x 1,5.

Nominal diameter: DN100.

Gas seal: leakage rate $\leq 1 \times 10^{-6}$ mbar x l/s⁻¹ (helium test with mass spectrometer).

Case: AISI 304.

Ring: bayonet lock, AISI 304 with antitampering sealing.

Window: glass.

Movement: stainless steel with bimetallic temperature compensator.

Dial: white aluminium with black markings and coloured sectors as per customer's specification.

Pointer: black anodised aluminium.

1.M5 - MCE10/SF6 : copper alloy wetted parts , suitable for indoor ambients

1 - Standard dry version

Process connection: OT58.

Sensing element: phosphor bronze.

Protection degree: IP 54 as per IEC 529, UNI 8896.

3 - Silicon oil filled version

Process connection: OT58.

Sensing element: phosphor bronze.

Protection degree: IP65 as per IEC 529, UNI 8896.

Window: safety glass.

1.M6 - MCE18/SF6 : AISI 316L wetted parts, suitable for outdoor ambients

1 - Standard dry version

Process connection and sensing element: AISI 316L.

Protection degree: IP 54 as per IEC 529, UNI 8896.

3 - Silicon oil filled version

Process connection and sensing element: AISI 316L.

Protection degree: IP 65 as per IEC 529, UNI 8896.

Window: safety glass.

9 - Nitrogen filled version

Process connection and sensing element: AISI 316L.

Protection degree: IP 65 as per IEC 529, UNI 8896.

Window: safety glass.

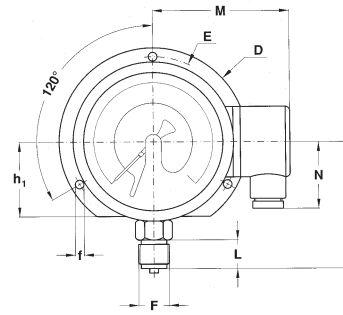
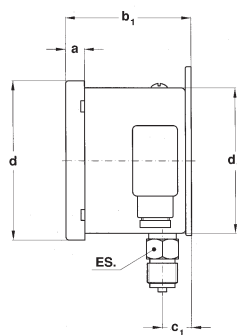
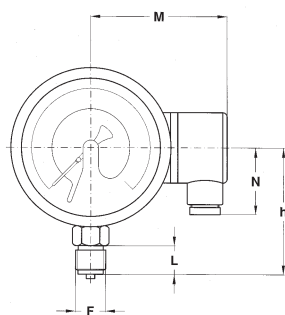
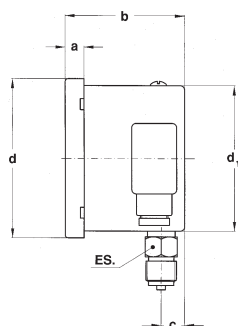

A
stem mounting;
lower connection.

A + C
surface mounting, back flange;
lower connection.

Type	F	a	b (1)	c	d	d ₁	f	h	h ₁	D	E	M	N	L	ES	Weight (1)(2)
A	41M G 1/2 A	0.51" (13)	2.87/3.27" (73/83)	0.63" (16)	4.33" (110)	3.98" (101)		3.50" (89)				3.70" (94)	1.81" (46)	0.79" (20)	0.87" (22)	1.45/1.65 lbs (0,66/0,75 kg)
A+C	43M 1/2-14 NPT	0.51" (13)	3.03/3.43" (77/87)	0.79" (20)	4.33" (110)	3.98" (101)	0.24" (6)	3.50" (89)	2.05" (52)	5.12" (130)	4.65" (118)	3.70" (94)	1.81" (46)	0.79" (20)	0.87" (22)	1.63/1.83 lbs (0,74/0,83 kg)

dimensions : inches (mm)

(1) dimensions for single or double contacts; (2) add 0.88 lbs (0,4 kg), when glycerine filled

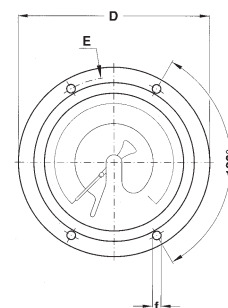
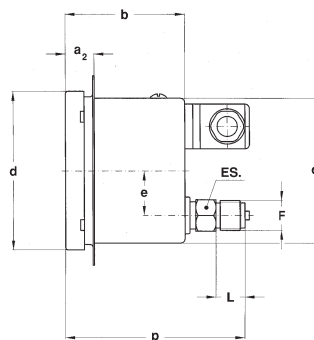
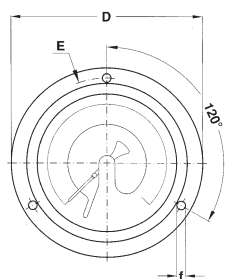
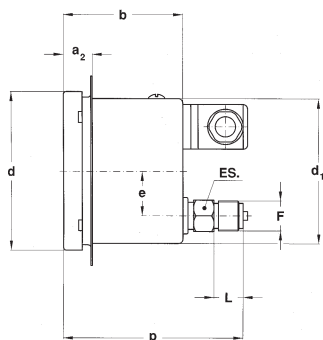

D + E
flush mounting, front flange 3 holes;
back connection.

D + Q
flush mounting, front flange 4 holes;
back connection.

Type	F	a ₂	b (1)	d	d ₁	e	f	p (1)	D	E	L	ES	Weight (1)(2)
D+E	41M G 1/2 A	0.79" (20)	2.87/3.27" (73/83)	4.33" (110)	3.98" (101)	1.22" (31)	0.24" (6)	4.49/4.88" (114/124)	5.20" (132)	4.65" (118)	0.79" (20)	0.87" (22)	1.41/1.61 lbs (0,64/0,73 kg)
D+Q	43M 1/2-14 NPT	0.79" (20)	2.87/3.27" (73/83)	4.33" (110)	3.98" (101)	1.22" (31)	0.24" (6)	4.49/4.88" (114/124)	5.20" (132)	4.65" (118)	0.79" (20)	0.87" (22)	1.41/1.61 lbs (0,64/0,73 kg)

dimensions : inches (mm)

(1) dimensions for single or double contacts; (2) add 0.88 lbs (0,4 kg), when glycerine filled

Pressure gauges for SF₆ gas monitoring

DS 4" (100 mm)

MCE10-18/SF6

Magnetic snap action contacts

Set-point hysteresis: 2...5% f.s.v.

Break rating: 30W/50VA (20W/20VA if filled).

Maximum rating: 250Vca/1A (ohmic load).

Minimum rating: 24 Vcc/20 mA (ohmic rating).

Contact material: Silver-Nickel 80/20%.

Electrical wiring: with junction box as per VDE, see table page 4.

LOAD RATINGS, as per DIN 16085.

Volt	Dry versions or filled with azote			Silicon dielectric oil filled versions		
	CC	CA	Inductive load	CC	CA	Inductive load
220	100 mA	120 mA	65 mA	65 mA	90 mA	40 mA
110	200 mA	240 mA	130 mA	130 mA	180 mA	85 mA
48	300 mA	450 mA	200 mA	190 mA	330 mA	130 mA
24	400 mA	600 mA	250 mA	250 mA	450 mA	150 mA

WIRING SCHEME (The numbers shown are the same as those are indicated on the junction box)	THE PRESSURE RAISING MEANS...	CONTACT CODE
...FOR SINGLE CONTACTS		
	<u>Opening PS1</u>	01S
	<u>Closing PS1</u>	02S
... FOR DOUBLE CONTACTS		
	<u>Opening PS1</u> <u>Opening PS2</u> (each contact must not exceed the next one)	06D
	<u>Closing PS1</u> <u>Closing PS2</u> (each contact must not exceed the next one)	09D

Inductive electric contacts

Electric wiring: with junction box as per VDE, see table page 4.

Set-point hysteresis: 0,3...1% f.s.v.

WIRING SCHEME (The numbers shown are the same as those are indicated on the junction box)	THE PRESSURE RAISING MEANS...	CONTACT CODE
FOR SINGLE CONTACTS...		
	<u>Opening PS1</u>	B1
	<u>Closing PS1</u>	B2
FOR DOUBLE CONTACTS...		
	<u>Opening PS1</u> <u>Opening PS2</u> (each contact must not exceed the next one)	B11
	<u>Closing PS1</u> <u>Closing PS2</u> (each contact must not exceed the next one)	B22

RANGES

bar	-1...+0,6	-1...+1,5	-1...+3	-1...+5	-1...+9	-1...+15	-1...+24
MPa	-0,1...+0,06	-0,1...+0,15	-0,1...+0,3	-0,1...+0,5	-0,1...+0,9	-0,1...+1,5	-0,1...+2,4

RECOMMENDATION

The measuring of the temperature necessary to the termic compensation it is detected inside the instrument. This means that these instruments should be installed so that their operating temperature corresponds to the one of the monitored SF₆ gas.

In order to avoid any compensating error due to the different isochores, the **PC** calibration must be as nearest as possible to the **PS** contacts setting pressure.

HOW TO ORDER

1° - DESCRIPTION & CODE
Model 1.M5 - MCE 10 SF6, for indoor ambients 1.M6 - MCE 18 SF6, for outdoor ambients
Version 1 - Standard, dry 3 - Filled with silicon dielectric oil version 9 - Filled with azote oil version
Mounting type A - lower connection - stem mounting D - back connection - front flange 3 holes
Technical specification code To be asked to the Technical & Commercial Service
Ranges : from 1,6 to 25 bar, also vacuum and compound
Process connection 41M - 1/2" BSP - G 1/2 A - PF 1/2 43M - 1/2" NPT
Electric schemes : 01S...B22 - see tabels on page 3
Mounting accessories C - Back flange, for lower connection pressure gauge E - 3 holes front flange, for back connection pressure gauge Q - 4 holes front flange, for back connection pressure gauge

2° - CALIBRATION FEATURES
PF - nominal pressure of the circuit filling
PC - calibration pressure, which identifies the reference isochore
PS1 - setting pressure of the contact PS1, on the temperature of SF ₆ gas of 20°C ...and if the contacts are two
PS2 - setting pressure of the contactPS2, on the temperature of SF ₆ gas of 20°C
3° - DIAL LAYOUT
1° : red sector range
2° : orange sector range
3° : green sector range



standard version : DS 1.5", 2" (40-50mm)

MS1

RANGES	bar	kPa	MPa
0...1			AB
0...1,6			AB
0...2,5	AB		AB
0...4	AB		AB
0...6	AB		B
0...10	AB		B
0...16	AB		B
0...25	AB		B
0...40	AB		B
0...60	B		
0...100	B		
0...160	B		
0...250	B	AB	
0...400	B	AB	
0...600		AB	
0...1000		AB	
0...1600		AB	
0...2500		AB	

"A" = DS 1.5"(40mm); "B" = DS 2" (50mm).

standard version : DS 6" (150mm)

RANGES	bar (1)	kPa	MPa	bar ext.	psi int.
0...1	+		+		+
0...1,6	+		+		+
0...2,5	+		+		+
0...4	+		+		+
0...6	+		+		+
0...10	+		+		+
0...16	+		+		+
0...25	+		+		+
0...40	+		+		+
0...60	+	+	+		+
0...100	+	+	+		+
0...160	+	+			+
0...250	+	+			+
0...400	+	+			+
0...600	+	+			+
0...1000	+	+			+
0...1600		+			
0...2500		+			

(1) available also kg/cm²

RANGES	psi	psi int.	kPa ext.
0...15	+	+	
0...30	+	+	
0...60	+	+	
0...100	+	+	
0...160	+	+	
0...200	+	+	
0...300	+	+	
0...400	+	+	
0...600	+	+	
0...800	+	+	
0...1000	+	+	
0...1500	+	+	
0...2000	+	+	
0...3000	+	+	
0...4000	+	+	
0...5000	+	+	
0...6000	+	+	
0...10000	+	+	
0...15000	+	+	

RANGES	bar	kPa	bar ext.	psi int.*
-1...0	+			+
-1...0,6	+			+
-1...1,5	+			+
-1...3	+			+
-1...5	+			+
-1...9	+			+
-1...15	+			+
-1...24	+			+
-100...0		+		
-100...150		+		
-100...300		+		
-100...500		+		
-100...900		+		
-100...1500		+		

* vacuum measurement unit : "inHg"

RANGES	psi*	psi int.*	kPa ext.
-30...0	+	+	
-30...15	+	+	
-30...30	+	+	
-30...150	+		

* vacuum measurement unit : "inHg"

standard version : DS 1.5", 2", 2.5" (40-50-63mm)

MS2

RANGES	bar
-1...0	C
0...1	C
0...1,6	C
0...2,5	ABC
0...4	ABC
0...6	ABC
0...10	ABC
0...16	ABC
0...25	ABC
0...40	ABC

RANGES	psi
0...15	C
0...30	ABC
0...60	ABC
0...100	ABC
0...160	ABC
0...200	ABC
0...300	ABC
0...400	ABC
0...500	ABC
0...600	ABC

"A" = DS 1.5"(40mm); "B" = DS 2" (50mm); "C" = DS 2.5"(63mm).

bourdon tube pressure gauges : available ranges

case painted stainless steel : DS 1.5", 2", 2.5" (40-50-63mm)

MS3-MS7

RANGES	bar
-1...0	C
0...1	C
0...1,6	C
0...2,5	ABC
0...4	ABC
0...6	ABC
0...10	ABC
0...16	ABC
0...25	ABC
0...40	ABC
0...60	ABC
0...100	ABC
0...160	ABC
0...250	ABC

RANGES	psi
0...15	C
0...30	ABC
0...60	ABC
0...100	ABC
0...160	ABC
0...200	ABC
0...300	ABC
0...400	ABC
0...500	ABC
0...600	ABC
0...1000	ABC
0...1500	ABC
0...2000	ABC
0...3000	ABC

"A" = DS 1.5"(40mm); "B" = DS 2" (50mm); "C" = DS 2.5"(63mm).

anti-vibration version : DS 4" (100mm)

MS4

RANGES	bar (1)	kPa	MPa	bar ext.	bar ext.	bar ext.
				psi int.	kPa int.	MPa int.
0...1	+			+	+	
0...1,6	+			+	+	
0...2,5	+			+	+	
0...4	+			+	+	
0...6	+			+	+	
0...10	+			+		+
0...16	+			+		+
0...25	+			+		+
0...40	+			+		+
0...60	+			+		+
0...100	+	+		+		+
0...160	+	+		+		+
0...250	+	+		+		+
0...300	+					
0...400	+	+		+		+
0...600	+	+		+		+
0...1000	+	+		+		+
0...1600		+				
0...2500		+				

RANGES	psi	psi ext.	psi ext.
		bar int.	kg/cm ² int.
0...15	+	+	+
0...30	+	+	+
0...60	+	+	+
0...100	+	+	+
0...160	+	+	+
0...200	+	+	+
0...300	+	+	+
0...400	+	+	+
0...600	+	+	+
0...1000	+	+	+
0...1500	+	+	+
0...2000	+	+	+
0...3000	+	+	+
0...4000	+	+	+
0...5000	+	+	+
0...6000	+	+	+
0...10000	+	+	+
0...15000	+	+	+

RANGES	bar	kPa	bar ext.	bar ext.
			psi int.*	kPa int.
-1...0	+		+	+
-1...0,6	+		+	+
-1...1,5	+		+	+
-1...3	+		+	+
-1...5	+		+	+
-1...9	+		+	+
-1...15	+		+	+
-1...24	+		+	+
-100...0		+		
-100...150		+		
-100...300		+		
-100...500		+		
-100...900		+		
-100...1500		+		
-100...2400		+		

RANGES	psi*	psi ext.*	psi ext.*
		Bar int.	kg/cm ² int.
-30...0	+	+	+
-30...15	+	+	+
-30...30	+	+	+
-30...150	+	+	

* vacuum measurement unit : "inHg"

* vacuum measurement unit : "inHg"

(1) Available also kg/cm²

aluminium case : DS 10" (250mm)

MGS8

RANGES	bar	kg/cm ²	kPa	MPa
0...1	+	+		+
0...1,6	+	+		+
0...2,5	+	+		+
0...4	+	+		+
0...6	+	+		+
0...10	+	+		+
0...16	+	+		+
0...25	+	+		+
0...40	+	+		+
0...60	+	+		+
0...100	+	+	+	+
0...160	+	+	+	
0...250	+	+	+	
0...400	+	+	+	
0...600	+	+	+	
0...1000	+	+	+	
0...1600			+	
0...2500			+	

RANGES	psi
0...60	+
0...100	+
0...300	+
0...400	+
0...600	+
0...1000	+
0...1600	+

stainless steel bourdon tube : DS 4" (100mm)

MGS44

RANGES	bar	kPa	MPa	bar ext.
				psi int.
0...1	✦		✦	✦
0...1,6	✦		✦	✦
0...2,5	✦		✦	✦
0...4	✦		✦	✦
0...6	✦		✦	✦
0...10	✦		✦	✦
0...16	✦		✦	✦
0...25	✦		✦	✦
0...40	✦		✦	✦
0...60	✦			✦
0...100	✦	✦		✦
0...160	✦	✦		✦
0...250	✦	✦		✦
0...300	✦			
0...400	✦	✦		✦
0...600		✦		
0...1000		✦		
0...1600		✦		
0...2500		✦		

RANGES	psi
0...15	✦
0...30	✦
0...60	✦
0...100	✦
0...160	✦
0...200	✦
0...300	✦
0...400	✦
0...600	✦
0...1000	✦
0...1500	✦
0...2000	✦
0...3000	✦
0...4000	✦
0...6000	✦

anti-vibrations version : DS 2" (50mm)

MGS10

RANGES	bar	kPa	MPa	bar ext.
				psi int.
0...2,5	✦		✦	✦
0...4	✦		✦	✦
0...6	✦		✦	✦
0...10	✦		✦	✦
0...16	✦		✦	✦
0...25	✦		✦	✦
0...40	✦		✦	✦
0...60	✦			✦
0...100	✦			✦
0...160	✦			✦
0...250	✦	✦		✦
0...400	✦	✦		✦
0...600		✦		
0...1000		✦		
0...1600		✦		
0...2500		✦		

bourdon tube pressure gauges : available ranges

anti-vibrations version : DS 2.5" (63mm)

MGS10

RANGES	bar	kPa	MPa	bar ext. psi int.	bar ext. kPa int.	bar ext. MPa int.
0...1	+		+	+	+	
0...1,6	+		+	+	+	
0...2,5	+		+	+	+	
0...4	+		+	+	+	
0...6	+		+	+	+	
0...10	+		+			+
0...16	+		+	+	+	+
0...25	+		+	+	+	+
0...40	+		+	+	+	+
0...60	+		+	+	+	+
0...100	+	+		+	+	+
0...160	+	+		+	+	+
0...250	+	+		+	+	+
0...300	+			+		
0...400	+	+		+		+
0...600	+	+		+		+
0...1000		+				
0...1600		+				
0...2500		+				

RANGES	psi	psi int.	psi ext.	psi ext.
	kPa ext.	bar int.	kg/cm ² int.	
0...15	+	+	+	+
0...30	+	+	+	+
0...60	+	+	+	+
0...100	+	+	+	+
0...160	+	+	+	+
0...200	+	+	+	+
0...300	+	+	+	+
0...400	+	+	+	+
0...500	+	+	+	+
0...600	+	+	+	+
0...1000	+	+	+	+
0...1500	+	+	+	+
0...2000	+	+	+	+
0...3000	+	+	+	+
0...4000	+	+	+	+
0...5000	+	+	+	+
0...6000	+	+	+	+
0...10000	+	+	+	+

RANGES	bar	kPa	bar ext. *psi int.	bar ext. kPa int.
-1...0	+		+	+
-1...0,6	+		+	+
-1...1,5	+		+	+
-1...3	+		+	+
-1...5	+		+	+
-1...9	+		+	+
-1...15	+		+	+
-1...24	+		+	+
-100...0		+		
-100...150		+		
-100...300		+		
-100...500		+		
-100...900		+		
-100...1500		+		

RANGES	* psi	* psi int.	* psi ext.	* psi ext.
	kPa ext.	bar int.	kg/cm ² int.	
-30...0	+	+	+	+
-30...15	+	+	+	+
-30...30	+	+	+	+
-30...150	+		+	

* vacuum measurement unit: "inHg"

* vacuum measurement unit: "inHg"

anti-vibrations version : DS 4" (100mm)

MGS10

RANGES	bar	kPa	MPa	bar ext. psi int.	bar ext. kPa int.	bar ext. MPa int.
0...1	+		+	+	+	
0...1,6	+		+	+	+	
0...2,5	+		+	+	+	
0...4	+		+	+	+	
0...6	+		+	+	+	
0...10	+		+	+		+
0...16	+		+	+	+	+
0...25	+		+	+	+	+
0...40	+		+	+	+	+
0...60	+		+	+	+	+
0...100	+	+		+	+	+
0...160	+	+		+	+	+
0...250	+	+		+	+	+
0...300	+			+		
0...400	+	+		+		+
0...600	+	+		+		+
0...1000		+				
0...1600		+				
0...2500		+				

RANGES	psi	psi int.	psi ext.	psi ext.
	kPa ext.	bar int.	kg/cm ² int.	
0...15	+	+	+	+
0...30	+	+	+	+
0...60	+	+	+	+
0...100	+	+	+	+
0...160	+	+	+	+
0...200	+	+	+	+
0...300	+	+	+	+
0...400	+	+	+	+
0...600	+	+	+	+
0...800	+	+	+	+
0...1000	+	+	+	+
0...1500	+	+	+	+
0...2000	+	+	+	+
0...3000	+	+	+	+
0...4000	+	+	+	+
0...5000	+	+	+	+
0...6000	+	+	+	+
0...10000	+	+	+	+
0...15000	+	+	+	+

RANGES	bar	kPa	bar ext. *psi int.*	bar ext. kPa int.
-1...0	+		+	+
-1...0,6	+		+	+
-1...1,5	+		+	+
-1...3	+		+	+
-1...5	+		+	+
-1...9	+		+	+
-1...15	+		+	+
-1...24	+		+	+
-100...0		+		
-100...150		+		
-100...300		+		
-100...500		+		
-100...900		+		
-100...1500		+		
-100...2400		+		

RANGES	psi*	psi int.*	psi ext.*	psi ext.*
	kPa ext.	bar int.	kg/cm ² int.	
-30...0	+	+	+	+
-30...15	+	+	+	+
-30...30	+	+	+	+
-30...150	+		+	

* vacuum measurement unit: "inHg"

* vacuum measurement unit: "inHg"

all stainless steel construction : DS 1.5", 2" (40-50mm)

MGS18

RANGES	bar	kPa	MPa
0...2,5	+		+
0...4	+		+
0...6	+		
0...10	+		
0...16	+		
0...25	+		
0...40	+		
0...250		+	
0...400		+	
0...600		+	
0...1000		+	
0...1600		+	
0...2500		+	

all stainless steel construction : DS 2.5" (63mm)

MGS18

RANGES	bar	kPa	MPa	bar ext. psi int.	bar ext. kPa int.	bar ext. MPa int.
0...1	+			+	+	
0...1,6	+			+	+	
0...2,5	+			+	+	
0...4	+			+	+	
0...6	+			+	+	
0...10	+			+	+	+
0...16	+			+	+	+
0...25	+			+	+	+
0...40	+			+	+	+
0...60	+			+	+	+
0...100	+	+	+	+	+	+
0...160	+	+		+	+	+
0...250	+	+		+	+	+
0...300	+			+		
0...400	+	+		+		+
0...600	+	+		+		+
0...1000	+	+		+		+
0...1600	+					
0...2500		+				

RANGES	psi	psi выт. kPa ext.	psi ext. bar int.	psi ext. kg/cm ² int.
0...15	+	+	+	+
0...30	+	+	+	+
0...60	+	+	+	+
0...100	+	+	+	+
0...160	+	+	+	+
0...200	+	+	+	+
0...300	+	+	+	+
0...400	+	+	+	+
0...600	+	+	+	+
0...1000	+	+	+	+
0...1500	+	+	+	+
0...2000	+	+	+	+
0...3000	+	+	+	+
0...4000	+	+	+	+
0...5000	+	+	+	+
0...6000	+	+	+	+
0...10000	+	+	+	+
0...15000	+	+	+	+

RANGES	bar	kPa	bar ext. psi int.*	bar ext. kPa int.
-1...0	+		+	+
-1...0,6	+		+	+
-1...1,5	+		+	+
-1...3	+		+	+
-1...5	+		+	+
-1...9	+		+	+
-1...15	+		+	+
-1...24	+		+	+
-100...0		+		
-100...150		+		
-100...300		+		
-100...500		+		
-100...900		+		
-100...1500		+		

RANGES	psi*	psi int.* kPa ext.	psi ext.* bar int.	psi ext.* kg/cm ² int.
-30...0	+	+	+	+
-30...15	+	+	+	+
-30...30	+	+	+	+
-30...150	+		+	

* vacuum measurement unit : "inHg"

* vacuum measurement unit : "inHg"

all stainless steel construction : DS 4", 6" (100-150mm)

MGS18

"E" = DS 4" (100mm); "G" = DS 6" (150mm)

RANGES	bar	kPa	MPa	bar ext. psi int.	bar ext. kPa int.	bar ext. MPa int.
0...0,6 (1)	E G			E G	E G	
0...1	E G			E G	E G	
0...1,6	E G			E G	E G	
0...2,5	E G			E G	E G	
0...4	E G			E G	E G	
0...6	E G			E G	E G	
0...10	E G			E G	E G	E G
0...16	E G			E G	E G	E G
0...25	E G			E G	E G	E G
0...40	E G			E G	E G	E G
0...60	E G	E G (1)		E G	E G	E G
0...100	E G	E G		E G	E G	E G
0...160	E G	E G		E G	E G	E G
0...250	E G	E G		E G	E G	E G
0...300	E G					
0...400	E G	E G		E G	E G	E G
0...600	E G	E G		E G	E G	E G
0...1000	E G	E G		E G	E G	E G
0...1600	E G	E G		E G	E G	E G
0...2500		E G				

(1) not available for filled model

RANGES	psi	psi int. kPa ext.	psi ext. bar int.	psi ext. kg/cm ² int.
0...15	E G	E G	E G	E G
0...30	E G	E G	E G	E G
0...60	E G	E G	E G	E G
0...100	E G	E G	E G	E G
0...160	E G	E G	E G	E G
0...200	E G	E G	E G	E G
0...300	E G	E G	E G	E G
0...400	E G	E G	E G	E G
0...600	E G	E G	E G	E G
0...1000	E G	E G	E G	E G
0...1500	E G	E G	E G	E G
0...2000	E G	E G	E G	E G
0...3000	E G	E G	E G	E G
0...4000	E G	E G	E G	E G
0...5000	E G	E G	E G	E G
0...6000	E G	E G	E G	E G
0...10000	E G	E G	E G	E G
0...15000	E G	E G	E G	E G
0...20000	E G	E G	E G	E G
0...30000 (1)	E G	E G	E G	E G

(1) working pressure: max 75% of FSV
overpressure: 10% of FSV

RANGES	bar	kPa	bar ext. psi int.*	bar ext. kPa int.
-1...0	E G		E G	E G
-1...0,6	E G		E G	E G
-1...1,5	E G		E G	E G
-1...3	E G		E G	E G
-1...5	E G		E G	E G
-1...9	E G		E G	E G
-1...15	E G		E G	E G
-1...24	E G		E G	E G
-100...0		E G		
-100...150		E G		
-100...300		E G		
-100...500		E G		
-100...900		E G		
-100...1500		E G		
-100...2400		E G		

* vacuum measurement unit : "inHg"

RANGES	psi*	psi int.* kPa ext.	psi ext.* bar int.	psi ext.* kg/cm ² int.
-30...0	E G	E G	E G	E G
-30...15	E G	E G	E G	E G
-30...30	E G	E G	E G	E G
-30...150	E G	/	E G	/

* vacuum measurement unit : "inHg"

"solid-front" version, all stainless steel construction : DS 2.5" (63mm)

MGS20

RANGES	bar	kPa	MPa
0...1	+		+
0...1,6	+		+
0...2,5	+		+
0...4	+		+
0...6	+		+
0...10	+		+
0...16	+		+
0...25	+		+
0...40	+		+
0...60	+		+
0...100	+	+	+
0...160	+	+	
0...250	+	+	
0...300	+		
0...400	+	+	
0...600	+	+	
0...1000	+	+	
0...1600	+		
0...2500		+	

RANGES	psi
0...15	+
0...30	+
0...60	+
0...100	+
0...160	+
0...200	+
0...300	+
0...400	+
0...600	+
0...1000	+
0...1500	+
0...2000	+
0...3000	+
0...4000	+
0...5000	+
0...6000	+
0...10000	+
0...15000	+

RANGES	bar	kPa
-1...0	+	
-1...0,6	+	
-1...1,5	+	
-1...3	+	
-1...5	+	
-1...9	+	
-1...15	+	
-1...24	+	
-100...0		+
-100...150		+
-100...300		+
-100...500		+
-100...900		+
-100...1500		+

* vacuum measurement unit : "inHg"

RANGES	psi*
-30...0	+
-30...15	+
-30...30	+
-30...150	+

* vacuum measurement unit : "inHg"

bourdon tube pressure gauges : available ranges

"solid-front" version, all stainless steel construction : DS4", 6" (100-150mm)

MGS20

"E" = DS 4" (100mm); "G" = DS 6" (150mm)

RANGES	bar	kPa	MPa	bar ext.	bar ext.	bar ext.
				psi int.	kPa int.	MPa int.
0...0,6 (1)	E G			E G	E G	
0...1	E G		E G	E G	E G	
0...1,6	E G		E G	E G	E G	
0...2,5	E G		E G	E G	E G	
0...4	E G		E G	E G	E G	
0...6	E G		E G	E G	E G	
0...10	E G		E G	E G		E G
0...16	E G		E G	E G		E G
0...25	E G		E G	E G		E G
0...40	E G		E G	E G		E G
0...60	E G	E G (1)	E G	E G		E G
0...100	E G	E G	E G	E G		E G
0...160	E G	E G	E G	E G		E G
0...250	E G	E G		E G		E G
0...300	E G					
0...400	E G	E G		E G		E G
0...600	E G	E G		E G		E G
0...1000	E G	E G		E G		E G
0...1600	E G	E G		E G		E G
0...2500		E G				

(1) not available for filled model

RANGES	psi	psi bhydr.	psi ext.	psi ext.
		kPa ext.	bar int.	kg/cm ² int.
0...15	E G	E G	E G	E G
0...30	E G	E G	E G	E G
0...60	E G	E G	E G	E G
0...100	E G	E G	E G	E G
0...160	E G	E G	E G	E G
0...200	E G	E G	E G	E G
0...300	E G	E G	E G	E G
0...400	E G	E G	E G	E G
0...600	E G	E G	E G	E G
0...1000	E G	E G	E G	E G
0...1500	E G	E G	E G	E G
0...2000	E G	E G	E G	E G
0...3000	E G	E G	E G	E G
0...4000	E G	E G	E G	E G
0...5000	E G	E G	E G	E G
0...6000	E G	E G	E G	E G
0...10000	E G	E G	E G	E G
0...15000	E G	E G	E G	E G
0...20000	E G	E G	E G	E G
0...30000 (1)	E G	E G	E G	E G

(1) working pressure: max 75% of FSV
overpressure: 10% of FSV

RANGES	bar	kPa	bar ext.	bar ext.
			psi int.*	kPa int.
-1...0	E G		E G	E G
-1...0,6	E G		E G	E G
-1...1,5	E G		E G	E G
-1...3	E G		E G	E G
-1...5	E G		E G	E G
-1...9	E G		E G	E G
-1...15	E G		E G	E G
-1...24	E G		E G	E G
-100...0		E G		
-100...150		E G		
-100...300		E G		
-100...500		E G		
-100...900		E G		
-100...1500		E G		
-100...2400		E		

* vacuum measurement unit : "inHg"

RANGES	psi*	psi int.*	psi ext.*	psi ext.*
		kPa ext.	bar int.	kg/cm ² int.
-30...0	E G	E G	E G	E G
-30...15	E G	E G	E G	E G
-30...30	E G	E G	E G	E G
-30...150	E G	/	E G	/

* vacuum measurement unit : "inHg"

"solid-front" version, turret case : DS 4.5" (125mm)

MGS30

RANGES	bar	kPa	MPa	bar ext.
				psi int.
0...0,6	♦(1)			♦(1)
0...1	♦			♦
0...1,6	♦			♦
0...2,5	♦			♦
0...4	♦			♦
0...6	♦			♦
0...10	♦			♦
0...16	♦			♦
0...25	♦			♦
0...40	♦			♦
0...60	♦	♦(1)		♦
0...100	♦	♦	♦(3)	♦
0...160	♦	♦	♦(3)	♦
0...250	♦	♦		♦
0...300	♦			♦
0...400	♦	♦		♦
0...600	♦	♦		♦
0...1000	♦(3)	♦		♦(3)
0...1600	♦(3)	♦		♦(3)
0...2500		♦		

RANGES	psi	psi int.	psi ext.
		kPa ext.	bar int.
0...15	♦	♦	♦
0...30	♦	♦	♦
0...60	♦	♦	♦
0...100	♦	♦	♦
0...160	♦	♦	♦
0...200	♦	♦	♦
0...300	♦	♦	♦
0...400	♦	♦	♦
0...600	♦	♦	♦
0...800	♦	♦	♦
0...1000	♦	♦	♦
0...1500	♦	♦	♦
0...2000	♦	♦	♦
0...3000	♦	♦	♦
0...4000	♦	♦	♦
0...5000	♦	♦	♦
0...6000	♦	♦	♦
0...10000	♦	♦	♦
0...15000(3)	♦	♦	♦
0...20000(3)	♦	♦	♦
0...30000(2)(3)	♦	♦	♦

RANGES	bar	kPa
-1...0	♦	
-1...0,6	♦	
-1...1,5	♦	
-1...3	♦	
-1...5	♦	
-1...9	♦	
-1...15	♦	
-1...24	♦	
-100...0		♦
-100...150		♦
-100...300		♦
-100...500		♦
-100...900		♦
-100...1500		♦
-100...2400		♦

RANGES	psi*	psi int.*
		kPa ext.
-30...0	♦	♦
-30...15	♦	♦
-30...30	♦	♦
-30...60	♦	♦
-30...100	♦	♦
-30...150	♦	♦

* vacuum measurement unit : "inHg"

(1) not available for filled model
(2) working pressure: max 75% of FSV; overpressure: 10% of FSV
(3) with decreasing pressure, the accuracy is max 1,2% of FSV

"solid-front" version, turret case : DS 4.5" (125mm)

MGS30

EXTRA

RANGES	bar	kPa	MPa
0...1			♦
0...1,6			♦
0...2,5	♦		♦
0...4	♦		♦
0...6	♦		♦
0...10	♦		♦
0...16	♦		♦
0...25	♦		♦
0...40	♦		♦
0...60	♦		♦
0...100	♦		♦
0...160	♦		♦
0...250	♦	♦	
0...300	♦	♦	
0...400	♦	♦	
0...600	♦	♦	
0...1000	♦	♦	
0...1600	♦	♦	
0...2500		♦	

RANGES	psi	psi int.
		kPa ext.
0...30	♦	♦
0...60	♦	♦
0...100	♦	♦
0...160	♦	♦
0...200	♦	♦
0...300	♦	♦
0...400	♦	♦
0...600	♦	♦
0...800	♦	♦
0...1000	♦	♦
0...1500	♦	♦
0...2000	♦	♦
0...3000	♦	♦
0...4000	♦	♦
0...5000	♦	♦
0...6000	♦	♦
0...10000	♦	♦
0...15000	♦	♦

RANGES	bar
-1...1,5	♦
-1...3	♦
-1...5	♦
-1...9	♦
-1...15	♦
-1...24	♦

RANGES	psi*	psi int.*
		kPa ext.
-30...15	♦	♦
-30...30	♦	♦
-30...60	♦	♦
-30...100	♦	♦
-30...150	♦	♦
-30...200	♦	♦
-30...300	♦	♦

* vacuum measurement unit : "inHg"

NACE MR 01.03 version : DS 4", 6" (100-150mm)

MGS36-37

"E" = DS 4" (100mm); "G" = DS 6" (150mm)

RANGES	bar	kPa	MPa
0...1	EG		EG
0...1,6	EG		EG
0...2,5	EG		EG
0...4	EG		EG
0...6	EG		EG
0...10	EG		EG
0...16	EG		EG
0...25	EG		EG
0...40	EG		EG
0...60	EG		EG
0...100	EG	EG	
0...160	EG	EG	
0...250	EG	EG	
0...300	EG		
0...400	EG	EG	
0...600	EG	EG	

RANGES	psi
0...15	EG
0...30	EG
0...60	EG
0...100	EG
0...160	EG
0...200	EG
0...300	EG
0...400	EG
0...600	EG
0...1000	EG
0...1500	EG
0...2000	EG
0...3000	EG
0...4000	EG
0...5000	EG
0...6000	EG

RANGES	bar	kPa
-1...0	EG	
-1...0,6	EG	
-1...1,5	EG	
-1...3	EG	
-1...5	EG	
-1...9	EG	
-1...15	EG	
-1...24	EG	
-100...0		EG
-100...150		EG
-100...300		EG
-100...500		EG
-100...900		EG
-100...1500		EG
-100...2400		E

RANGES	psi*
-30...0	EG
-30...15	EG
-30...30	EG
-30...150	EG

* vacuum unit of measurement: "inHg"

* vacuum unit of measurement: "inHg"

"solid-front" NACE MR 01.03 version : DS 4", 6" (100-150mm)

MGS40-41

"E" = DS 4" (100mm); "G" = DS 6" (150mm)

RANGES	bar	kPa	MPa
0...1	EG		EG
0...1,6	EG		EG
0...2,5	EG		EG
0...4	EG		EG
0...6	EG		EG
0...10	EG		EG
0...16	EG		EG
0...25	EG		EG
0...40	EG		EG
0...60	EG		EG
0...100	EG	EG	
0...160	EG	EG	
0...250	EG	EG	
0...300	EG		
0...400	EG	EG	
0...600	EG	EG	

RANGES	psi
0...15	EG
0...30	EG
0...60	EG
0...100	EG
0...160	EG
0...200	EG
0...300	EG
0...400	EG
0...600	EG
0...1000	EG
0...1500	EG
0...2000	EG
0...3000	EG
0...4000	EG
0...6000	EG
0...10000	EG

RANGES	bar	kPa
-1...0	EG	
-1...0,6	EG	
-1...1,5	EG	
-1...3	EG	
-1...5	EG	
-1...9	EG	
-1...15	EG	
-1...24	EG	
-100...0		EG
-100...150		EG
-100...300		EG
-100...500		EG
-100...900		EG
-100...1500		EG
-100...2400		E

RANGES	psi*
-30...0	EG
-30...15	EG
-30...30	EG
-30...150	EG

* vacuum unit of measurement: "inHg"

* vacuum unit of measurement: "inHg"

"solid-front" NACE MR 01.03 version, turret case : DS 4.5" (125mm)

MGS60-61

RANGES	bar	kPa	MPa
0...1	+		+
0...1,6	+		+
0...2,5	+		+
0...4	+		+
0...6	+		+
0...10	+		+
0...16	+		+
0...25	+		+
0...40	+		+
0...60	+		+
0...100	+	+	
0...160	+	+	
0...250	+	+	
0...300	+		
0...400	+	+	
0...600	+	+	

RANGES	psi
0...15	+
0...30	+
0...60	+
0...100	+
0...160	+
0...200	+
0...300	+
0...400	+
0...600	+
0...800	+
0...1000	+
0...1500	+
0...2000	+
0...3000	+
0...4000	+
0...6000	+
0...10000	+

RANGES	bar	kPa
-1...0	+	
-1...0,6	+	
-1...1,5	+	
-1...3	+	
-1...5	+	
-1...9	+	
-1...15	+	
-1...24	+	
-100...0		+
-100...150		+
-100...300		+
-100...500		+
-100...900		+
-100...1500		+
-100...2400		+

RANGES	psi*
-30...0	+
-30...15	+
-30...30	+
-30...60	+
-30...100	+
-30...150	+

* vacuum unit of measurement: "inHg"

bourdon tube pressure gauges : available ranges

with microswitch electric contact : DS 4" (100mm)

MGS72-74

Ranges	bar	kPa	MPa
0...1	+		+
0...1,6	+		+
0...2,5	+		+
0...4	+		+
0...6	+		+
0...10	+		+
0...16	+		+
0...25	+		+
0...40	+		+
0...60	+		+
0...100	+	+	
0...160	+	+	
0...250	+	+	
0...300	+		
0...400	+	+	
0...600	+	+	
0...1000		+	
0...1600		+	
0...2500		+	

Ranges	psi
0...15	+
0...30	+
0...60	+
0...100	+
0...160	+
0...200	+
0...300	+
0...400	+
0...600	+
0...800	+
0...1000	+
0...1500	+
0...2000	+
0...3000	+
0...4000	+
0...5000	+
0...6000	+
0...10000	+

Ranges	bar	kPa
-1...0	+	
-1...0,6	+	
-1...1,5	+	
-1...3	+	
-1...5	+	
-1...9	+	
-1...15	+	
-1...24	+	
-100...0		+
-100...150		+
-100...300		+
-100...500		+
-100...900		+
-100...1500		+
-100...2400		+

* vacuum unit of measurement: "inHg"

Ranges	psi*
-30...0	+
-30...15	+

* vacuum unit of measurement: "inHg"

MCE10-18

with electric, inductive or electronic contact : DS 4" (100 mm)

Ranges	bar	kPa	MPa
0...1	+		+
0...1,6	+		+
0...2,5	+		+
0...4	+		+
0...6	+		+
0...10	+		+
0...16	+		+
0...25	+		+
0...40	+		+
0...60	+		+
0...100	+	+	+
0...160	+	+	+
0...250	+	+	
0...400	+	+	
0...600	+	+	
0...1000	+	+	
0...1600 (1)	+	+	

(1) Available only for MCE18

Ranges	psi
0...15 (1)	+
0...30	+
0...60	+
0...100	+
0...160	+
0...200	+
0...300	+
0...400	+
0...600	+
0...1000	+
0...1500	+
0...2000	+
0...3000	+
0...4000	+
0...5000	+
0...6000	+
0...10000	+
0...15000	+
0...20000 (1)	+

MCE20

with electric, inductive or electronic contact : DS 6" (150 mm)

Ranges	bar	kPa	MPa
0...1	+		+
0...1,6	+		+
0...2,5	+		+
0...4	+		+
0...6	+		+
0...10	+		+
0...16	+		+
0...25	+		+
0...40	+		+
0...60	+		+
0...100	+	+	+
0...160	+	+	+
0...250	+	+	
0...400	+	+	
0...600	+	+	
0...1000	+	+	
0...1600	+	+	

Ranges	psi
0...15	+
0...30	+
0...60	+
0...100	+
0...160	+
0...200	+
0...300	+
0...400	+
0...500	+
0...600	+
0...1000	+
0...1500	+
0...2000	+
0...3000	+
0...4000	+
0...5000	+
0...6000	+
0...10000	+
0...15000	+
0...20000	+

bourdon tube pressure gauges : mounting

back flange lower connection pressure gauges

Model	DS	b_1	h_1	E	D	f
MGS10	2.5 (63)	1.34 (34)	1.36 (34,5)	2.95 (75)	3.35 (85)	0.14 (3,6)
MGS18	2.5 (63)	1.48 (37,5) (1)	1.36 (34,5)	2.95 (75)	3.35 (85)	0.14 (3,6)
MS4-MGS44	4 (100)	1.49 (38)	2.05 (52)	4.57...4.72 (116...120)	5.12 (130)	0.24 (6)
MGS10-18-19-36	4 (100)	2.07 (52,5)	2.05 (52)	4.57...4.72 (116...120)	5.12 (130)	0.24 (6)
MGS20-21-40	4 (100)	2.85 (72,5)	-	4.57...4.72 (116...120)	5.20 (132)	0.24 (6)
MN14/10-18	4 (100)	2.07 (52,5)	2.05 (52)	4.57...4.72 (116...120)	5.12 (130)	0.24 (6)
MCE10-18	4 (100)	3.01...3.41 (76,5...86,5)	2.05 (52)	4.57...4.72 (116...120)	5.12 (130)	0.24 (6)
MGS72-74	4 (100)	2.07 (52,5)	2.05 (52)	4.57...4.72 (116...120)	5.12 (130)	0.24 (6)
MS1	6 (150)	2.13 (54)	3.35 (85)	6.61...7.01 (168...178)	7.48 (190)	0.24 (6)
MGS18-19-36	6 (150)	2.13 (54)	3.35 (85)	6.61...7.01 (168...178)	7.48 (190)	0.24 (6)
MGS20-21-40	6 (150)	2.97 (75,5)	3.35 (85)	6.61...7.01 (168...178)	7.48 (190)	0.24 (6)
MN15	6 (150)	2.13 (54)	3.35 (85)	6.61...7.01 (168...178)	7.48 (190)	0.24 (6)
MN16-17	6 (150)	2.97 (75,5)	3.35 (85)	6.61...7.01 (168...178)	7.48 (190)	0.24 (6)
MN25	6 (150)	-	3.35 (85)	6.61...7.01 (168...178)	7.48 (190)	0.24 (6)
MN14/10-18	6 (150)	2.13 (54)	3.35 (85)	6.61...7.01 (168...178)	7.48 (190)	0.24 (6)
MCE20	6 (150)	5.49 (139,5)	3.35 (85)	6.61...7.01 (168...178)	7.48 (190)	0.24 (6)

dimensions : inches (mm)

(1) 1.32 (33,5) with crimped ring
(2) 0.61 (15,5) with crimped ring

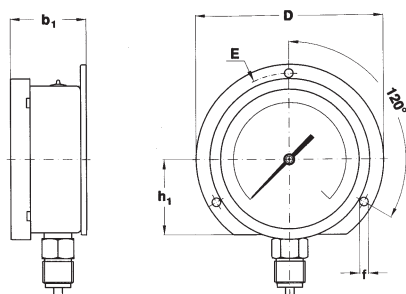

C - BACK FLANGE,
for lower connection

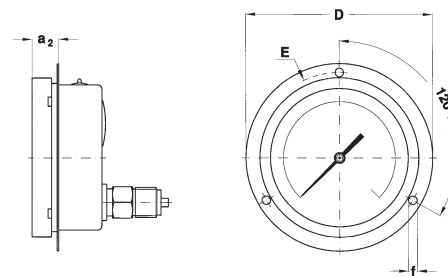

E - FRONT FLANGE,
for back connection

front flange back connection pressure gauges

Model	DS	a_2	E	D	f
MGS10	2.5 (63)	0.26 (6,6)	2.95 (75)	3.35 (85)	0.14 (3,6)
MGS18	2.5 (63)	0.26 (6,6)	2.95 (75)	3.35 (85)	0.14 (3,6)
MGS20	2.5 (63)	0.45 (11,5)	2.95 (75)	3.35 (85)	0.14 (3,6)
MS4 - MGS44	4 (100)	0.71 (18)	4.57...4.72 (116...120)	5.20 (132)	0.24 (6)
MGS10	4 (100)	0.79 (20)	4.57...4.72 (116...120)	5.20 (132)	0.24 (6)
MGS18-19-36	4 (100)	0.79 (20)	4.57...4.72 (116...120)	5.20 (132)	0.24 (6)
MGS20-21-40	4 (100)	0.79 (20)	4.57...4.72 (116...120)	5.20 (132)	0.24 (6)
MN14/10-18	4 (100)	0.79 (20)	4.57...4.72 (116...120)	5.20 (132)	0.24 (6)
MCE10-18	4 (100)	0.79 (20)	4.57...4.72 (116...120)	5.20 (132)	0.24 (6)
MGS72-74	4 (100)	0.79 (20)	4.57...4.72 (116...120)	5.20 (132)	0.24 (6)
MGS18-19-36	6 (150)	1 (25,5)	6.61...7.01 (168...178)	7.48 (190)	0.24 (6)
MGS20-21-40	6 (150)	1 (25,5)	6.61...7.01 (168...178)	7.48 (190)	0.24 (6)
MN15	6 (150)	1 (25,5)	6.61...7.01 (168...178)	7.48 (190)	0.24 (6)
MN16-17	6 (150)	1 (25,5)	6.61...7.01 (168...178)	7.48 (190)	0.24 (6)
MN25	6 (150)	1 (25,5)	6.61...7.01 (168...178)	7.48 (190)	0.24 (6)
MN14/10-18	4 (100)	0.79 (20)	4.57...4.72 (116...120)	5.20 (132)	0.24 (6)

dimensions : inches (mm)

bourdon tube pressure gauges : mounting

back flange lower connection for solid-front pressure gauges

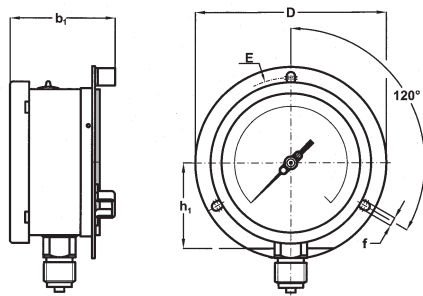

C - BACK FLANGE,
for lower connection

Model	DS	b ₁	h ₁	f	D	E
MGS20-21-40	4 (100)	2.85 (72,5)	-	0.24 (6)	5.19 (132)	4.56...4.72 (116...120)
MGS20-21-40	6 (150)	2.85 (72,5)	3.34 (85)	0.24 (6)	7.48 (190)	6.61...7.00 (168...178)

clamp back connection pressure gauges

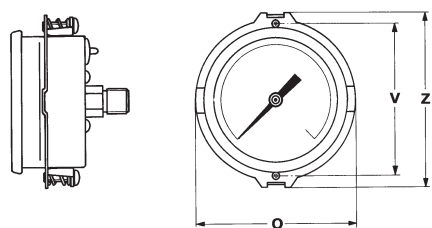

Model	DS	Q	Z	V
MS1, MGS10-18	2 (50)	2.46 (62,6)	2.66 (67,5)	2.30 (58,5)

dimensions : inches (mm)

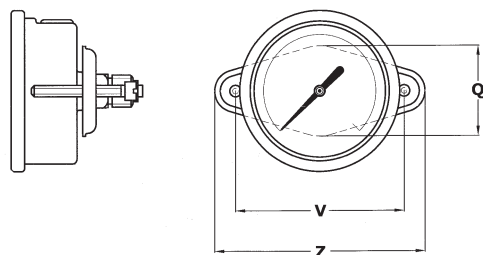

Model	DS	Q	Z	V
MGS10-18	2.5 (63)	1.50 (38)	3.54 (90)	2.83 (72)

dimensions : inches (mm)

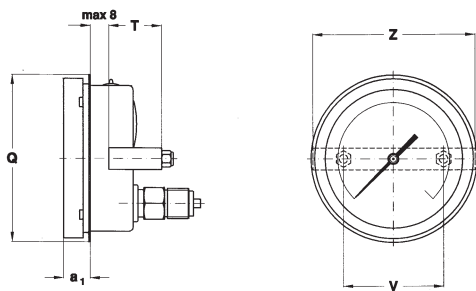

B - "U" CLAMP,
for back connection

Model	DS	Q	a ₁	T	Z	V
MS4	4 (100)	---	---	1.2 (30,5)	4.41 (112)	2.76 (70)
MGS10-18-19-36	4 (100)	4.41 (112)	0.79 (20)	1.63 (41,5)	4.41 (112)	2.76 (70)
MN14/10-18	4 (100)	4.41 (112)	0.79 (20)	1.63 (41,5)	4.41 (112)	2.76 (70)
MGS72-74	4 (100)	4.41 (112)	0.79 (20)	1.63 (41,5)	4.41 (112)	2.76 (70)
MS1	6 (150)	6.46 (164)	0.81 (20,5)	1.63 (41,5)	6.10 (155)	4.17 (106)
MGS18-19-36	6 (150)	6.46 (164)	0.81 (20,5)	1.63 (41,5)	6.10 (155)	4.17 (106)
MN15	6 (150)	6.46 (164)	0.81 (20,5)	1.63 (41,5)	6.10 (155)	4.17 (106)
MN14/10-18	6 (150)	6.46 (164)	0.81 (20,5)	1.63 (41,5)	6.10 (155)	4.17 (106)

dimensions : inches (mm)

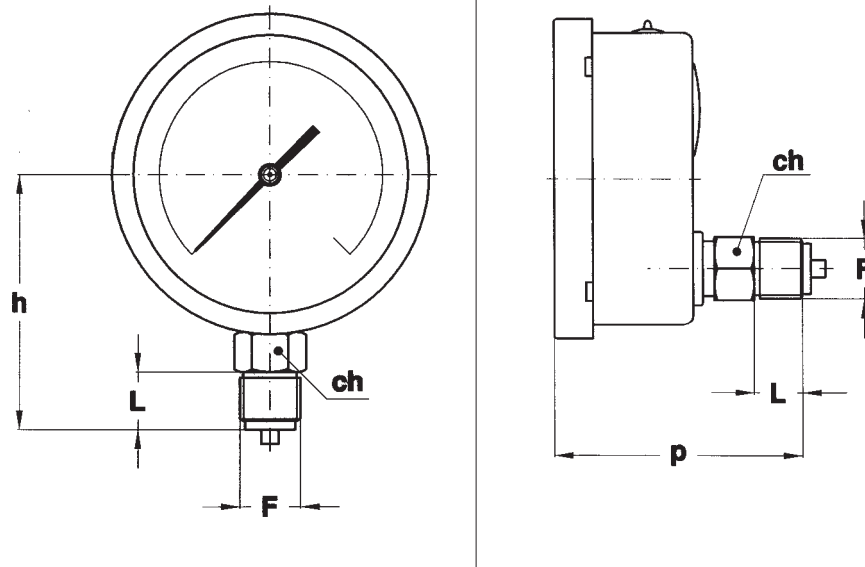

standard version

MS1

F	Cod.	DS 1.5" (40mm)			DS 2" (50mm)			DS 12" (50mm)				
		p	ch	L	h	p	ch	L	h	p	ch	L
G 1/8 B	11M	1.77 (45)	0.47 (12)	0.39 (10)	1.75 (44,5)	1.81 (46)	0.55 (14) ⁽¹⁾	0.39 (10)				
1/8-18 NPT	13M	1.77 (45)	0.47 (12)	0.39 (10)	1.75 (44,5)	1.81 (46)	0.55 (14) ⁽¹⁾	0.39 (10)				
G 1/4 B	21M	1.88 (48)	0.47 (12)	0.51 (13)	1.87 (47,5)	1.94 (49,5)	0.55 (14) ⁽¹⁾	0.51 (13)				
1/4-18 NPT	23M	2.04 (52)	0.47 (12)	0.59 (15)	1.94 (49,5)	2.10 (53,5)	0.55 (14) ⁽¹⁾	0.59 (15)	4.40 (112)	3.30 (84)	0.86 (22)	0.59 (15)
G 1/2 B	41M								4.60 (117)	3.50 (89)	0.86 (22)	0.78 (20)
1/2-14 NPT	43M								4.60 (117)	3.50 (89)	0.86 (22)	0.78 (20)

(1) ch= 0.47 (12) if back connection

dimensions : inches (mm)

anti-vibrations version

MS4

F	Cod.	DS 4" (100mm)			
		h	p	ch	L
G 1/4 B	21M	3.14 (80)	2.63 (67)	0.86 (22)	0.51 (13)
R 1/4-ISO 7/1	22M	3.22 (82)	2.71 (69)	0.86 (22)	0.59 (15)
1/4-18 NPT	23M	3.22 (82)	2.71 (69)	0.86 (22)	0.59 (15)
7/16-20UNF	24M	3.22 (82)	2.71 (69)	0.86 (22)	0.59 (15)
G 3/8 B	31M	3.26 (83)	2.75 (70)	0.86 (22)	0.62 (16)
G 1/2 B	41M	3.42 (87)	2.92 (74)	0.86 (22)	0.78 (20)
R 1/2-ISO 7/1	42M	3.42 (87)	2.92 (74)	0.86 (22)	0.78 (20)
1/2-14 NPT	43M	3.42 (87)	2.92 (74)	0.86 (22)	0.78 (20)
M 20 x 1,5	97M	3.42 (87)	2.92 (74)	0.86 (22)	0.78 (20)

dimensions : inches (mm)

stainless steel bourdon tube



F	Cod.	DS 4" (100mm)		
		h	ch	L
1/4-18 NPT	23M	3.22 (82)	0.87 (22)	0.59 (15)
1/2-14 NPT	43M	3.42 (87)	0.87 (22)	0.79 (20)

dimensions : inches (mm)

bourdon tube pressure gauges : threaded process connections

anti-vibrations version

MG10

F	Cod.	DS 2" (50mm)				DS 2.5" (63mm)				DS 4" (100mm)			
		h	p	ch	L	h	p	ch	L	h	p	ch	L
G 1/8 B	11M	1.75 (44,5)	1.81 (46)	0.55 (14) ⁽¹⁾	0.39 (10)	2.08 (53)	2.08 (53)	0.55 (14)	0.39 (10)				
1/8-18 NPT	13M	1.75 (44,5)	1.81 (46)	0.55 (14) ⁽¹⁾	0.39 (10)	2.08 (53)	2.08 (53)	0.55 (14)	0.39 (10)				
G 1/4 B	21M	1.87 (47,5)	1.94 (49,5)	0.55 (14) ⁽¹⁾	0.51 (13)	2.16 (55)	2.16 (55)	0.55 (14)	0.51 (13)	3.18 (81)	3.26 (83)	0.86 (22)	0.51 (13)
1/4-18 NPT	23M	1.94 (49,5)	2.10 (53,5)	0.55 (14) ⁽¹⁾	0.59 (15)	2.12 (54)	2.12 (54)	0.55 (14)	0.51 (13)	3.26 (83)	3.34 (85)	0.86 (22)	0.59 (15)
M10X1	86M					2.08 (53)	2.08 (53)	0.55 (14)	0.39 (10)			0.86 (22)	
R1/4-ISO7/1	22M					2.12 (54)	2.12 (54)	0.55 (14)	0.51 (13)	3.26 (83)	3.34 (85)	0.86 (22)	0.59 (15)
7/16-20UNF	24M					2.20 (56)	2.20 (56)	0.55 (14)	0.55 (14)	3.26 (83)	3.34 (85)	0.86 (22)	0.59 (15)
G 3/8 B	31M									3.30 (84)	3.38 (86)	0.86 (22)	0.62 (16)
G 1/2 B	41M									3.46 (88)	3.54 (90)	0.86 (22)	0.78 (20)
1/2-14 NPT	43M									3.46 (88)	3.54 (90)	0.86 (22)	0.78 (20)
M20X1,5	97M									3.46 (88)	3.54 (90)	0.86 (22)	0.78 (20)

(1) ch= 0.47 (12) if back connection

dimensions : inches (mm)

all stainless steel version

MG18

F	Cod.	DS 1.5" (40mm)			DS 2" (50mm)				DS 2.5" (63mm)				DS 4" (100mm)				DS 6" (150mm)			
		p	ch	L	h	p	ch	L	h	p	ch	L	h	p	ch	L	h	p	ch	L
G 1/8 B	11M	1.73 (44)	0.47 (12)	0.39 (10)	1.75 (44,5)	1.81 (46)	0.55 ⁽¹⁾ (14) ⁽¹⁾	0.39 (10)	2.08 (53)	2.08 (53)	0.55 (14)	0.39 (10)								
1/8-18 NPT	13M	1.73 (44)	0.47 (12)	0.39 (10)	1.75 (44,5)	1.81 (46)	0.55 ⁽¹⁾ (14) ⁽¹⁾	0.39 (10)	2.08 (53)	2.08 (53)	0.55 (14)	0.39 (10)								
G 1/4 B	21M	1.92 (49)	0.47 (12)	0.51 (13)	1.87 (47,5)	2 (51)	0.55 ⁽¹⁾ (14) ⁽¹⁾	0.51 (13)	2.16 (55)	2.16 (55)	0.55 (14)	0.51 (13)	3.11 (79)	3.34 (85)	0.86 (22)	0.51 (13)	4.33 (110)	3.28 (83,5)	0.86 (22)	0.51 (13)
1/4-18 NPT	23M	2 (51)	0.47 (12)	0.59 (15)	1.94 (49,5)	2.08 (53)	0.55 ⁽¹⁾ (14) ⁽¹⁾	0.59 (15)	2.12 (54)	2.12 (54)	0.55 (14)	0.51 (13)	3.18 (81)	3.42 (87)	0.86 (22)	0.59 (15)	4.40 (112)	3.36 (85,5)	0.86 (22)	0.59 (15)
R1/4-ISO7/1	22M								2.12 (54)	2.12 (54)	0.55 (14)	0.51 (13)								
G 3/8 B	31M												3.38 (86)	3.42 (87)	0.86 (22)	0.62 (16)	4.44 (113)	3.36 (85,5)	0.86 (22)	0.62 (16)
3/8-18 NPT	33M												3.38 (86)	3.42 (87)	0.86 (22)	0.62 (16)	4.44 (113)	3.36 (85,5)	0.86 (22)	0.62 (16)
G 1/2 B	41M												3.38 (86)	3.42 (87)	0.86 (22)	0.78 (20)	4.6 (117)	3.36 (85,5)	0.86 (22)	0.78 (20)
R 1/2-ISO 7/1	42M												3.38 (86)	3.42 (87)	0.86 (22)	0.78 (20)	4.6 (117)	3.36 (85,5)	0.86 (22)	0.78 (20)
1/2-14 NPT	43M												3.38 (86)	3.42 (87)	0.86 (22)	0.78 (20)	4.6 (117)	3.36 (85,5)	0.86 (22)	0.78 (20)
M 20 x 1,5	97M												3.38 (86)	3.42 (87)	0.86 (22)	0.78 (20)	4.6 (117)	3.36 (85,5)	0.86 (22)	0.78 (20)

(1) ch= 0.47 (12) if back connection

dimensions : inches (mm)

all stainless steel version, heavy work

MGS19

F	Cod.	DS 4" (100mm)				DS 6" (150mm)			
		h	p	ch	L	h	p	ch	L
G 1/4 B	21M	3.11 (79)	3.35 (85)	0.87 (22)	0.51 (13)	4.33 (110)	3.29 (83,5)	0.87 (22)	0.51 (13)
1/4-18 NPT	23M	3.19 (81)	3.43 (87)	0.87 (22)	0.59 (15)	4.41 (112)	3.37 (85,5)	0.87 (22)	0.59 (15)
G 3/8 B	31M	3.39 (86)	3.43 (87)	0.87 (22)	0.63 (16)	4.45 (113)	3.37 (85,5)	0.87 (22)	0.63 (16)
3/8-18 NPT	33M	3.39 (86)	3.43 (87)	0.87 (22)	0.63 (16)	4.45 (113)	3.37 (85,5)	0.87 (22)	0.63 (16)
G 1/2 B	41M	3.39 (86)	3.43 (87)	0.87 (22)	0.79 (20)	4.61 (117)	3.37 (85,5)	0.87 (22)	0.79 (20)
R 1/2-ISO 7/1	42M	3.39 (86)	3.43 (87)	0.87 (22)	0.79 (20)	4.61 (117)	3.37 (85,5)	0.87 (22)	0.79 (20)
1/2-14 NPT	43M	3.39 (86)	3.43 (87)	0.87 (22)	0.79 (20)	4.61 (117)	3.37 (85,5)	0.87 (22)	0.79 (20)
M 20 x 1,5	97M	3.39 (86)	3.43 (87)	0.87 (22)	0.79 (20)	4.61 (117)	3.37 (85,5)	0.87 (22)	0.79 (20)

dimensions : inches (mm)

MGS20

F	Cod.	DN 2.5" (63mm)				DN 4" (100mm)				DN 6" (150mm)			
		h	p	ch	L	h	p	ch ⁽¹⁾	L	h	p	ch ⁽¹⁾	L
G 1/8 B	11M	2.08 (53)	2.28 (58)	0.55 (14)	0.39 (10)								
1/8-18 NPT	13M	2.08 (53)	2.28 (58)	0.55 (14)	0.39 (10)								
G 1/4 B	21M	2.16 (55)	2.36 (60)	0.55 (14)	0.51 (13)	3.11 (79)	3.68 (93,5)	0.87 (22)	0.51 (13)	4.33 (110)	3.70 (94)	0.87 (22)	0.51 (13)
1/4-18 NPT	23M	2.12 (54)	2.32 (59)	0.55 (14)	0.51 (13)	3.19 (81)	3.76 (95,5)	0.87 (22)	0.59 (15)	4.41 (112)	3.78 (96)	0.87 (22)	0.59 (15)
G 3/8 B	31M					3.39 (86)	3.76 (95,5)	0.87 (22)	0.63 (16)	4.45 (113)	3.78 (96)	0.87 (22)	0.63 (16)
3/8-18 NPT	33M					3.39 (86)	3.76 (95,5)	0.87 (22)	0.63 (16)	4.45 (113)	3.78 (96)	0.87 (22)	0.63 (16)
G 1/2 B	41M					3.39 (86)	3.76 (95,5)	0.87 (22)	0.79 (20)	4.61 (117)	3.78 (96)	0.87 (22)	0.79 (20)
R 1/2-ISO 7/1	42M					3.39 (86)	3.76 (95,5)	0.87 (22)	0.79 (20)	4.61 (117)	3.78 (96)	0.87 (22)	0.79 (20)
1/2-14 NPT	23M					3.39 (86)	3.76 (95,5)	0.87 (22)	0.79 (20)	4.61 (117)	3.78 (96)	0.87 (22)	0.79 (20)
M 20 x 1,5	97M					3.39 (86)	3.76 (95,5)	0.87 (22)	0.79 (20)	4.61 (117)	3.78 (96)	0.87 (22)	0.79 (20)

(1) ch= 0.67 (17) for back connection

dimensions : inches (mm)

bourdon tube pressure gauges : threaded process connection

all stainless steel version, "solid-front" heavy work

MGS21

F	Cod.	DS 4" (100mm)				DS 6" (150mm)			
		h	p	ch ⁽¹⁾	L	h	p	ch ⁽¹⁾	L
G 1/4 B	21M	3.11 (79)	3.68 (93,5)	0.87 (22)	0.51 (13)	4.33 (110)	3.70 (94)	0.87 (22)	0.51 (13)
1/4-18 NPT	23M	3.19 (81)	3.76 (95,5)	0.87 (22)	0.59 (15)	4.41 (112)	3.78 (96)	0.87 (22)	0.59 (15)
G 3/8 B	31M	3.39 (86)	3.76 (95,5)	0.87 (22)	0.63 (16)	4.45 (113)	3.78 (96)	0.87 (22)	0.63 (16)
3/8-18 NPT	33M	3.39 (86)	3.76 (95,5)	0.87 (22)	0.63 (16)	4.45 (113)	3.78 (96)	0.87 (22)	0.63 (16)
G 1/2 B	41M	3.39 (86)	3.76 (95,5)	0.87 (22)	0.79 (20)	4.61 (117)	3.78 (96)	0.87 (22)	0.79 (20)
R 1/2-ISO 7/1	42M	3.39 (86)	3.76 (95,5)	0.87 (22)	0.79 (20)	4.61 (117)	3.78 (96)	0.87 (22)	0.79 (20)
1/2-14 NPT	43M	3.39 (86)	3.76 (95,5)	0.87 (22)	0.79 (20)	4.61 (117)	3.78 (96)	0.87 (22)	0.79 (20)
M 20 x 1,5	97M	3.39 (86)	3.76 (95,5)	0.87 (22)	0.79 (20)	4.61 (117)	3.78 (96)	0.87 (22)	0.79 (20)

(1) ch= 0.66 (17) if back connection

all stainless steel test gauge, accuracy 0,6%

MN15

F	Cod.	DS 6" (150mm)			
		h	p	ch	L
G 1/4 B	21M	4.33 (110)	3.29 (83,5)	0.87 (22)	0.51 (13)
1/4-18 NPT	23M	4.41 (112)	3.37 (85,5)	0.87 (22)	0.59 (15)
G 1/2 B	41M	4.61 (117)	3.37 (85,5)	0.87 (22)	0.79 (20)
1/2-14 NPT	43M	4.61 (117)	3.37 (85,5)	0.87 (22)	0.79 (20)

dimensions : inches (mm)

all stainless steel test gauge, "solid-front" accuracy 0,6...0,25%

MN16-MN25

F	Cod.	DS 6" (150mm)			
		h	p	ch	L
G 1/4 B ⁽¹⁾	21M	4.33 (110)	3.74 (95)	0.87 (22) ⁽²⁾	0.51 (13)
1/4-18 NPT ⁽¹⁾	23M	4.41 (112)	3.82 (97)	0.87 (22) ⁽²⁾	0.59 (15)
G 1/2 B	41M	4.61 (117)	3.82 (97)	0.87 (22) ⁽²⁾	0.79 (20)
1/2-14 NPT	43M	4.61 (117)	3.82 (97)	0.87 (22) ⁽²⁾	0.79 (20)

(1) only for bottom connection on MN25
(2) ch= 0.67 (17) for back connection

dimensions : inches (mm)

test gauge, "solid-front", accuracy 0,25%

MN17

F	Cod.	DS 6" (150mm)			
		h	p	ch	L
G 1/4 B	21M	4.37 (111)	3.76 (95,5)	0.94 (24) ⁽¹⁾	0.51 (13)
1/4-18 NPT	23M	4.45 (113)	3.84 (97,5)	0.94 (24) ⁽¹⁾	0.59 (15)
G 1/2 B	41M	4.65 (118)	3.84 (97,5)	0.94 (24) ⁽¹⁾	0.79 (20)
1/2-14 NPT	43M	4.65 (118)	3.84 (97,5)	0.94 (24) ⁽¹⁾	0.79 (20)

(1) ch= 0.67 (17) for back connection

dimensions : inches (mm)

NACE MR 01.03 version

MG36

F	Cod.	DS 4" (100mm)				DS 6" (150mm)			
		h	p	ch	L	h	p	ch	L
G 1/2 B	41M	3.39 (86)	3.43 (87)	0.87 (22)	0.79 (20)	4.61 (117)	3.37 (85,5)	0.87 (22)	0.79 (20)
1/2-14 NPT	43M	3.39 (86)	3.43 (87)	0.87 (22)	0.79 (20)	4.61 (117)	3.37 (85,5)	0.87 (22)	0.79 (20)

dimensions : inches (mm)

NACE MR 01.03 version, "solid-front"

MG40

F	Cod.	DS 4" (100mm)				DS 6" (150mm)			
		h	p	ch	L	h	p	ch	L
G 1/2 B	41M	3.39 (86)	3.76 (95,5)	0.87 (22) ⁽¹⁾	0.79 (20)	4.61 (117)	3.78 (96)	0.87 (22) ⁽¹⁾	0.79 (20)
1/2-14 NPT	43M	3.39 (86)	3.76 (95,5)	0.87 (22) ⁽¹⁾	0.79 (20)	4.61 (117)	3.78 (96)	0.87 (22) ⁽¹⁾	0.79 (20)

(1) ch= 0.67 (17) for back connection

dimensions : inches (mm)

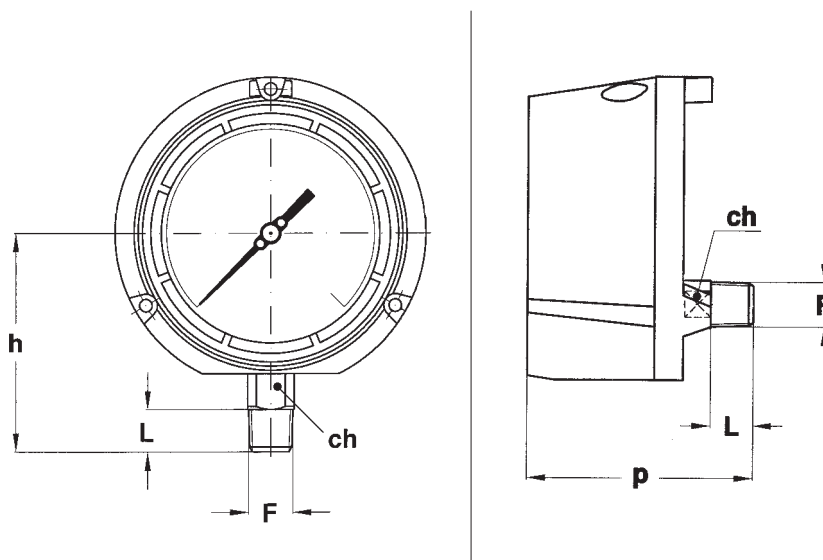

"solid-front" turret case

MG30-MGS30X

F	Cod.	DS 4.5" (125mm)			
		h	p	ch	L
1/4-18 NPT	23M	3.88 (98,5)	3.98 (101)	0.87 (22) ⁽¹⁾	0.59 (15)
1/2-14 NPT	43M	4.07 (103,5)	4.17 (106)	0.87 (22) ⁽¹⁾	0.79 (20)

(1) ch= 0.67 (17) for back connection

dimensions : inches (mm)

NACE MR 01.03 version, "solid-front" turret case

MG60

F	Cod.	DS 4.5" (125mm)			
		h	p	ch	L
1/4-18 NPT	23M	3.88 (98,5)	3.98 (101)	0.87 (22) ⁽¹⁾	0.59 (15)
1/2-14 NPT	43M	4.07 (103,5)	4.17 (106)	0.87 (22) ⁽¹⁾	0.79 (20)

(1) ch= 0.67 (17) for back connection

dimensions : inches (mm)

bourdon tube pressure gauges : threaded process connections

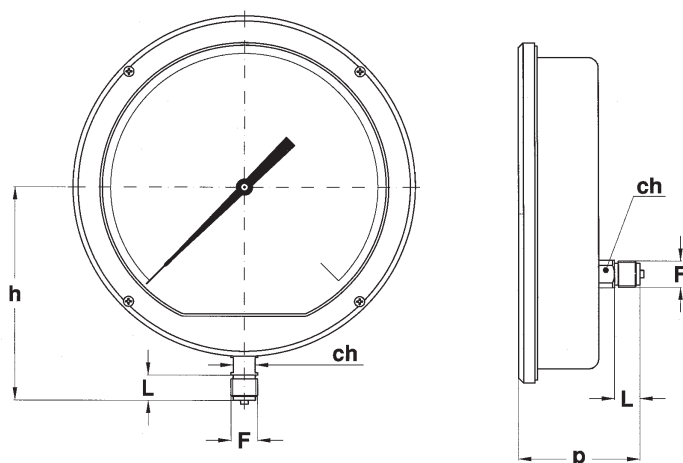

aluminium case

MGS8

F	Cod.	DS 10" (250mm)			
		h	p	ch	L
G 1/2 B	41M	6.69 (170)	3.72 (94,5)	0.66 (17) ⁽¹⁾	0.78 (20)
1/2-14 NPT	43M	6.69 (170)	3.72 (94,5)	0.66 (17) ⁽¹⁾	0.78 (20)

(1) ch= 0.87 (22) for back connection

dimensions : inches (mm)

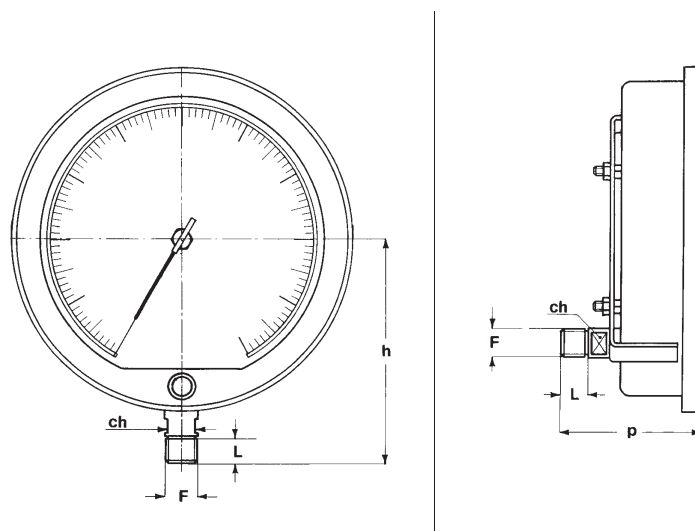

laboratory, accuracy 0,1%

MN17/L

F	Cod.	DS 10" (250mm)			
		h	p	ch	L
1/4-18 NPT	23M	6.50 (165)	4.39 (111,5)	0.67 (17)	0.59 (15)
G 1/2 B	41M	6.69 (170)	4.39 (111,5)	0.67 (17)	0.79 (20)
1/2-14 NPT	43M	6.69 (170)	4.39 (111,5)	0.67 (17)	0.79 (20)

dimensions : inches (mm)

bourdon tube pressure gauges : threaded process connection

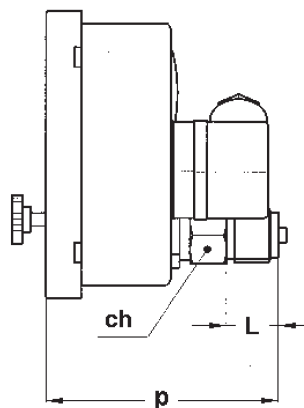
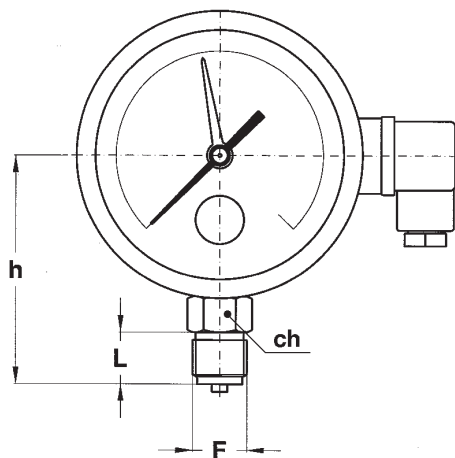

with microswitch

MGS72-74

F	Cod.	DS 4" (100mm)			
		h	p	ch	L
G 1/4 B	21M	3.18 (81)	3.27 (83)	0.87 (22)	0.51 (13)
1/4-18 NPT	23M	3.26 (83)	3.35 (85)	0.87 (22)	0.59 (15)
G 3/8 B	31M	3.30 (84)	3.39 (86)	0.87 (22)	0.63 (16)
3/8-18 NPT ⁽¹⁾	33M	3.30 (84)	3.39 (86)	0.87 (22)	0.63 (16)
G 1/2 B	41M	3.46 (88)	3.54 (90)	0.87 (22)	0.79 (20)
1/2-14 NPT	43M	3.46 (88)	3.54 (90)	0.87 (22)	0.79 (20)

(1) available for MGS72 only

dimensions : inches (mm)

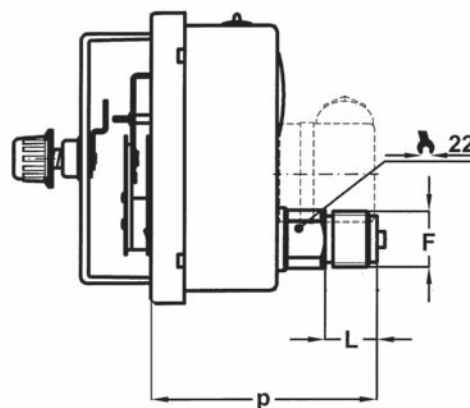
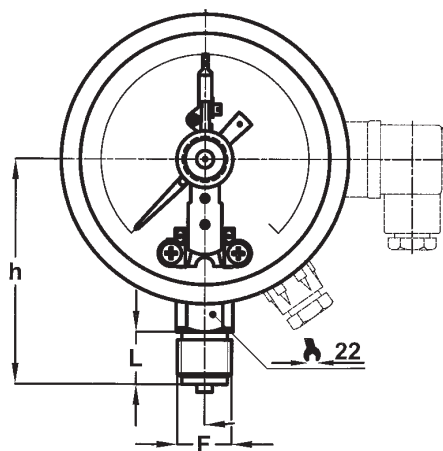

with electric contacts

MN14/10-18

F	Cod.	DS 4" (100mm)						DS 6" (150mm)					
		h ⁽¹⁾	h ⁽²⁾	p ⁽¹⁾	p ⁽²⁾	ch	L	h ⁽¹⁾	h ⁽²⁾	p ⁽¹⁾	p ⁽²⁾	ch	L
G 1/4 B	21M	3.19 (81)	3.11 (79)	3.26 (83)	3.34 (85)	0.87 (22)	0.51 (13)		4.33 (110)	3.22 (82)	3.28 (83,5)	0.87 (22)	0.51 (13)
1/4-18 NPT	23M	3.26 (83)	3.19 (81)	3.34 (85)	3.42 (87)	0.87 (22)	0.59 (15)	4.41 (112)	4.41 (112)	3.30 (84)	3.36 (85,5)	0.87 (22)	0.59 (15)
G 1/2 B	41M	3.46 (88)	3.39 (86)	3.54 (90)	3.42 (87)	0.87 (22)	0.79 (20)	4.61 (117)	4.61 (117)	3.50 (89)	3.36 (85,5)	0.87 (22)	0.79 (20)
R 1/2-ISO 7/1	42M	3.46 (88)	3.39 (86)	3.54 (90)	3.42 (87)	0.87 (22)	0.79 (20)		4.61 (117)	3.50 (89)	3.36 (85,5)	0.87 (22)	0.79 (20)
1/2-14 NPT	43M	3.46 (88)	3.39 (86)	3.54 (90)	3.42 (87)	0.87 (22)	0.79 (20)	4.61 (117)	4.61 (117)	3.50 (89)	3.36 (85,5)	0.87 (22)	0.79 (20)
M 20 x 1,5	97M	3.46 (88)	3.39 (86)	3.54 (90)	3.42 (87)	0.87 (22)	0.79 (20)		4.61 (117)	3.50 (89)	3.36 (85,5)	0.87 (22)	0.79 (20)

(1) MN14/10; (2) MN14/18

dimensions : inches (mm)

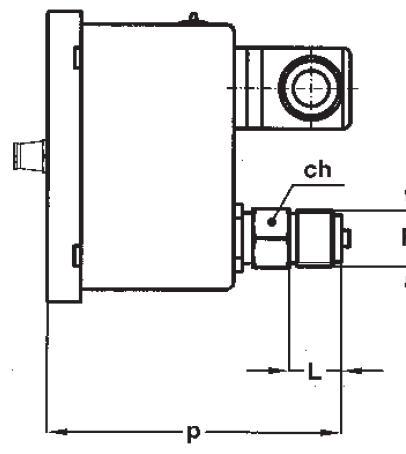
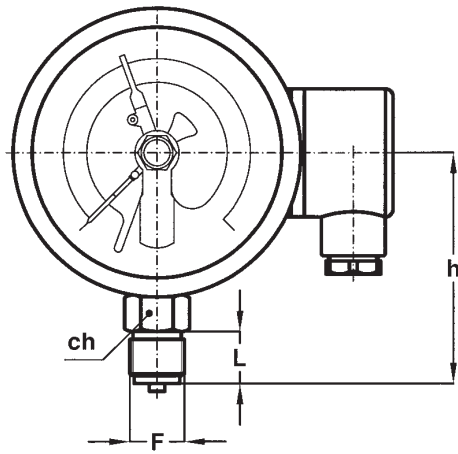

with electric contact

MCE10-18 MCE10-18/SF₆

F	Cod.	DS 4" (100mm)			
		h	p	ch	L
G 1/4 B	21M	3.18 (81)	4.21...4.61 (107...117)	0.87 (22)	0.51 (13)
1/4-18 NPT	23M	3.26 (83)	4.29...4.69 (109...119)	0.87 (22)	0.59 (15)
G 1/2 B	41M	3.46 (88)	4.49...4.88 (114...124)	0.87 (22)	0.79 (20)
1/2-14 NPT	43M	3.46 (88)	4.49...4.88 (114...124)	0.87 (22)	0.79 (20)

dimensions : inches (mm)

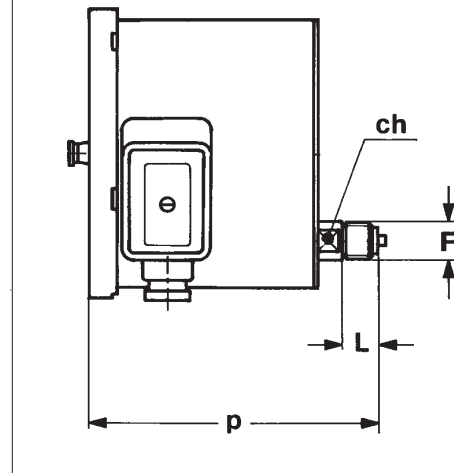
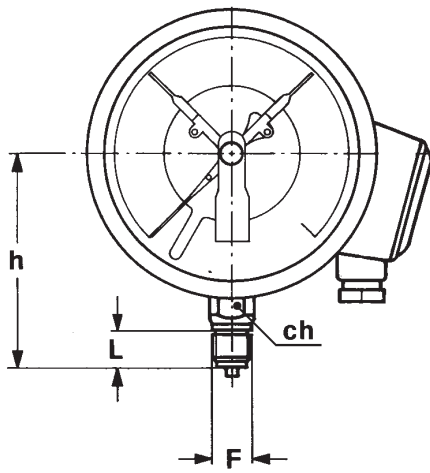

with electric contact

MCE20

F	Cod.	DS 6" (150mm)			
		h	p	ch	L
G 1/4 B ⁽²⁾	21M	4.33 (110)	6.22 (158)	0.87 (22)	0.51 (13)
1/4-18 NPT ⁽²⁾	23M	4.41 (112)	6.30 (160)	0.87 (22)	0.59 (15)
G 1/2 B	41M	4.61 (117)	6.30 (160)	0.87 (22) ⁽¹⁾	0.79 (20)
1/2-14 NPT	43M	4.61 (117)	6.30 (160)	0.87 (22) ⁽¹⁾	0.79 (20)

(1) ch= 0.67 (17) for back connection
 (2) for bottom connection only

dimensions : inches (mm)

Sliding contacts

The electrical sliding contacts guarantee an accurate operation within a controlled hysteresis. However they are rather sensitive to vibration, moreover, very slow pressure changes may cause an electric arc which can reduce its working life.

Magnetic Snap-Action Contacts

This type of contact is universally used to guarantee the reliable operation of gauges under severe vibration. The magnetic action is guaranteed by a "click operation", which improves contact capacity, life and is less sensitive to vibration. The required power to overcome the magnetic resistance causes an hysteresis at set-point between 2% to 5% of full scale value (from 4% to 10% of full scale value for double contacts).

Functional and constructive characteristics

Set-point accuracy: 150% of instrument accuracy.
Set-point hysteresis: 0,3% of full scale value.
Break rating: 10W / 18VA.
Maximum rating: 250Vac / 0,7A (ohmic load).
Contact material: Silver-Nickel 80 / 20%, gold plated.
Contact setting: over an arc of 270°, by a fixed key fitted to the front lens or by a removable key.
Electrical wiring: junction box with cable exit, as per instrument data-sheet.

Functional and constructive characteristics

Set-point accuracy: 150% of instrument accuracy.
Set-point hysteresis: 2...5% of full scale value.
Break rating: 30W / 50VA (20W / 20VA for filled version).
Maximum rating: 250Vac / 1A (ohmic load).
Contact material: Silver-Nickel 80 / 20%, gold plated.
Contact setting: from 10% to 90% of scale value by a fixed key fitted to the front lens or by a removable key.
Electrical wiring: junction box with cable exit, as per instrument data-sheet.

LOAD RATINGS (1)

Volt	DC	AC	Inductive load
220	40 mA	45 mA	25 mA
110	80 mA	90 mA	45 mA
48	120 mA	170 mA	70 mA
24	200 mA	350 mA	100 mA

Minimum values : 24V / 20mA / 0,4W / 4VA.

LOAD RATINGS (1)

Volt	DC	AC	Inductive load
220	100 mA	120 mA	65 mA
110	200 mA	240 mA	130 mA
48	300 mA	450 mA	200 mA
24	400 mA	600 mA	250 mA

Minimum values : 24V / 20mA / 0,4W / 4VA.

Dielectric silicone oil filled pressure gauges

Volt	CC	CA	Inductive load
220	65 mA	90 mA	40 mA
110	130 mA	180 mA	85 mA
48	190 mA	330 mA	130 mA
24	250 mA	450 mA	150 mA

Minimum values : 24V / 20mA / 0,4W / 4VA.

(1) as per DIN 16085.

CONTROL RELAYS

We recommend the use of control relays as they increase the working life of all types of contacts. For intrinsically safe applications an appropriate barrier must be used.

WIRING SCHEME (1)	ELECTRIC SCHEME (before set)	CLOCKWISE MOVEMENT OF THE POINTER CAUSES:	CONTACT CODE	
			sliding	magnetic snap-action
SINGLE CONTACT				
MINI 		<u>Opening</u>	01S	M1S
MAXI 		<u>Closing</u>	02S	M2S
DOUBLE CONTACT (2)				
1° MINI 2° MAXI 		<u>Opening 1</u> <u>Closing 2</u>	01D	M1D
1° MAXI 2° MAXI 		<u>Closing 1</u> <u>Closing 2</u>	02D	M2D
1° MAXI 2° MINI 		<u>Closing 1</u> <u>Opening 2</u>	03D	M3D
1° MINI 2° MINI 		<u>Opening 1</u> <u>Opening 2</u>	04D	M4D
INDEPENDENT DOUBLE CONTACT (2)				
1° MINI 2° MAXI 		<u>Opening 1</u> <u>Closing 2</u>	08D	M8D
1° MAXI 2° MAXI 		<u>Closing 1</u> <u>Closing 2</u>	09D	M9D

(1) The above numbers are the same of those stamped on the junction box.

(2) Each contact must not exceed the next one.

Electronic contacts with PNP output

Switching accuracy: 1,5 times the instrument accuracy.

Switching hysteresis: 0,3...1% of full scale value.

Adjustment: over an arc of 270°, through the knob placed on front lens or through removable key.

Supply: 10...30 Vdc.

Switching current: max 100 mA

Temperature range: -25...+65°C

Electronic contacts are equipped with electrical distance sensors (proximity sensors). The output signal is governed by the presence or absence of a control vane moved by the actual value pointer in the magnetic field of the proximity sensor.

The switching behaviour of the PNP switches used in these contacts is normally defined as a “closer” (opposite to the inductive contacts).

Due to their proximity type of switching, respect to the traditional sliding contact they offer better switching accuracy and extended service life.

They are properly designed to switch small DC load and so particularly suitable for a **direct wiring to PLC / PC** direct input and to trigger optoelectronic coupler.

Also they are the best preference for oil filled instruments to be installed in the most severe operating conditions created by the ambient environments.

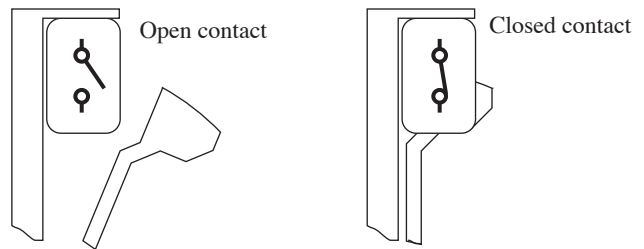

WIRING SCHEME (1)	ELECTRIC SCHEME (before set)	CLOCKWISE MOVEMENT OF THE POINTER CAUSES:	CONTACT CODE
SINGLE CONTACT			
MAXI 		<u>Closing</u>	E1
MINI 		<u>Opening</u>	E2
DOUBLE CONTACT (2)			
1° MAXI 2° MAXI 		<u>Closing 1</u> <u>Closing 2</u>	E11
1° MAXI 2° MINI 		<u>Closing 1</u> <u>Opening 2</u>	E12
1° MINI 2° MAXI 		<u>Opening 1</u> <u>Closing 2</u>	E21
1° MINI 2° MINI 		<u>Opening 1</u> <u>Opening 2</u>	E22

(1) The above numbers are the same of those stamped on the junction box.

(2) Each contact must not exceed the next one.

Inductive contacts are intrinsically safe and ATEX certified to EN 50014, EN 50020, EN 50284, IEC 61241-11 normes, with protection degree EEX ia IIC T6. They are incorporated in gauges and thermometers belonging to the group II with category 2GD and construction security protection "c". They are suitable to be installed in zones 1,2,22. To guarantee such protection degree the contacts must be supplied via a control relay which has the same type of certificate. When mounted on instruments with liquid filled case they are particularly suitable for application on chemical and petrochemical plants with vibrations and frequent operation.

B1 - 09 / 07

Functional and constructive characteristics

Set-point accuracy: 150% of instrument accuracy.

Set-point hysteresis: 0,3...1% of full scale value.

Contact setting: over an arc of 270 °, trough the knob placed on front lens or trough removable key.

Electric wiring: junction box as per VDE, see underdraw table.

Closed contact

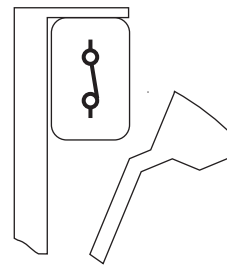

Open contact

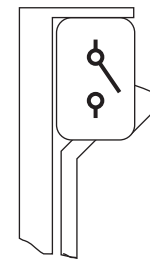

WIRING SCHEME (1)	ELECTRIC SCHEME (before set)	CLOCKWISE MOVEMENT OF THE POINTER CAUSES:	EX-CONTACT CODE
SINGLE CONTACT			
MINI 		Insertion of control flag into control head and <u>Opening</u>	B1
MAXI 		Release of control flag from control head and <u>Closing</u>	B2
DOUBLE CONTACT (2) (3)			
1° MINI 2° MAXI 		Insertion of control flag into control head n. 1, release of control flag from control head n. 2 and <u>Opening 1</u> <u>Closing 2</u>	B12
1° MAXI 2° MAXI 		Insertion of control flags into control heads <u>Closing 1-2</u>	B22

(1) The above numbers are the same of those stamped on the junction box.

(2) Each contact must not exceed the next one.

(3) Other electric contacts are available upon request.



NUOVA FIMA

NUOVA FIMA S.p.A.
P.O. BOX 58 Via Cesare Battisti, 59
28045 Inverio (NO) Italy
Tel. +39 0322.253200
Fax +39 0322.253232
info@nuovafima.com

www.nuovafima.com